

Notes for Math 112: Trigonometry

Instructor's Version

written by: Dr. Randall Paul

Further problems refer to:

Precalculus: Mathematics for Calculus, 4th ed.

by Stewart, Redlin, and Watson

January 4, 2017

©March 2015 Randall Paul

This work is licensed under the Creative Commons Attribution-NonCommercial-ShareAlike 3.0 Unported License. The essence of the license is that

You are free:

- **to Share** to copy, distribute and transmit the work
- **to Remix** to adapt the work

Under the following conditions:

- **Attribution** You must attribute the work in the manner specified by the author (but not in any way that suggests that they endorse you or your use of the work). Please contact the author at gregg.waterman@oit.edu to determine how best to make any attribution.
- **Noncommercial** You may not use this work for commercial purposes.
- **Share Alike** If you alter, transform, or build upon this work, you may distribute the resulting work only under the same or similar license to this one.

With the understanding that:

- **Waiver** Any of the above conditions can be waived if you get permission from the copyright holder.
- **Public Domain** Where the work or any of its elements is in the public domain under applicable law, that status is in no way affected by the license.
- **Other Rights** In no way are any of the following rights affected by the license:
 - ◇ Your fair dealing or fair use rights, or other applicable copyright exceptions and limitations;
 - ◇ The author's moral rights;
 - ◇ Rights other persons may have either in the work itself or in how the work is used, such as publicity or privacy rights.
- **Notice** For any reuse or distribution, you must make clear to others the license terms of this work. The best way to do this is with a link to the web page below.

To view a full copy of this license, visit <http://creativecommons.org/licenses/by-nc-sa/3.0/> or send a letter to Creative Commons, 444 Castro Street, Suite 900, Mountain View, California, 94041, USA.

Contents

1	Angles	5
1.1	Degrees and Radians	6
1.1.1	Co-terminal Angles	8
1.2	Radian Formulas	11
1.2.1	Arc-length	11
1.2.2	Angular Speed	12
1.2.3	Sector Area	14
2	Trigonometric Functions	17
2.1	Acute Angles	17
2.2	Unit Circle	22
2.2.1	Reference Angle	25
2.2.2	Definition of the Other Trig Functions	27
2.2.3	Pythagorean Identities	27
2.3	Graphs of Sine and Cosine	31
2.3.1	Amplitude and Period	32
2.3.2	Phase Shift and Vertical Shift	37
2.4	Other Trig Graphs	46
2.5	Inverse Trig Functions	53
2.5.1	Inverse Function Review	53
2.5.2	Inverse Sine	55
2.5.3	Inverse Cosine	58
2.5.4	Inverse Tangent	60
2.5.5	Inverse Applications	61
2.6	Trigonometric Equations	63
2.6.1	Simple Trigonometric Equations	63
2.6.2	More Complicated Trig Equations	66
3	Formulas	71
3.1	Identities	71
3.2	Sum and Difference Formulas	75
3.2.1	Writing a Sum as a Single Function	78
3.2.2	Product-to-sum and Sum-to-product Formulas	81
3.2.3	Double Angle Formulas	83
3.2.4	Half Angle Formulas	86

3.3	Complex Numbers	91
3.3.1	Trigonometric Form	91
3.3.2	Product, Quotient, and Power	94
3.3.3	Roots	96
4	Trigonometric Geometry	101
4.1	Law of Sines	101
4.1.1	Ambiguous Case	103
4.2	Law of Cosines	107
4.2.1	Triangle Area	111
4.3	Vectors	113
4.3.1	Trigonometric Form	115
4.3.2	Static Equilibrium	119

Chapter 1

Angles

Angles measure “turning”. Counterclockwise turns are described by positive angles, and clockwise turns negative angles.

Angles are described as a rotation taking one ray (called the ‘initial side’) to another ray (called the ‘terminal side’).

Example 1.1: A positive angle θ .

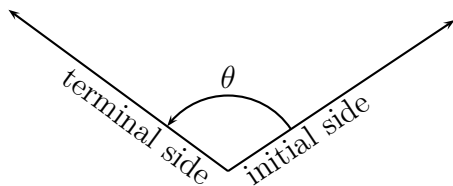

Example 1.2: A negative angle ϕ .

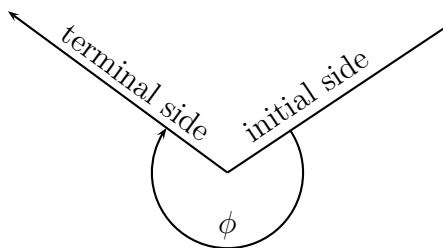

Notice that, though they have the same initial and terminal sides, θ and ϕ are **different angles**.

Definition: An angle is in **standard position** if its initial side is along the positive x -axis.

Example 1.3: Below is the angle θ from example 1.1 in standard position. (Same rotation, different initial and terminal sides.)

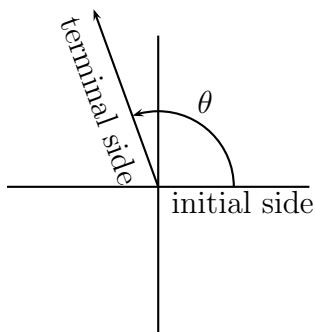

The x and y axes divide the plane into four **quadrants**. If an angle is in standard position, then its terminal side determines what quadrant the angle is in. For instance θ from example 1.3 is in quadrant II.

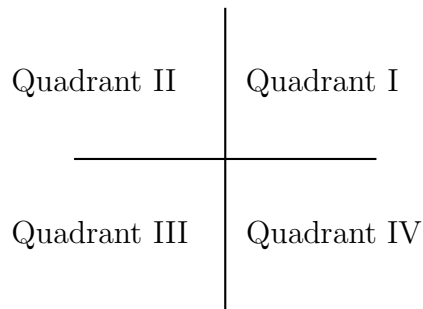

1.1 Degrees and Radians

There are two main units used to measure angles. In **degrees** a single, complete, counter-clockwise rotation is 360° . In **radians** it is 2π .

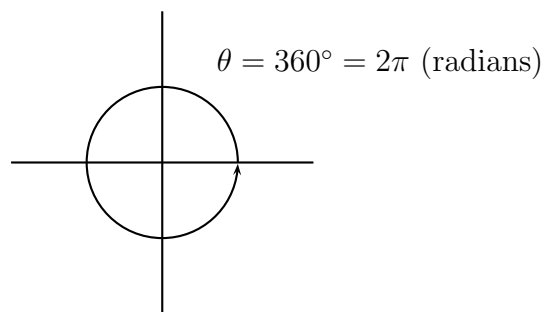

Thus a positive one quarter rotation would be: $\frac{1}{4}360^\circ = 90^\circ = \frac{1}{4}2\pi = \frac{\pi}{2}$

While a backwards one half rotation would be: $-\frac{1}{2}360^\circ = -180^\circ = -\frac{1}{2}2\pi = -\pi$

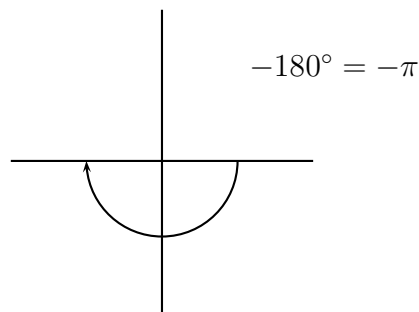
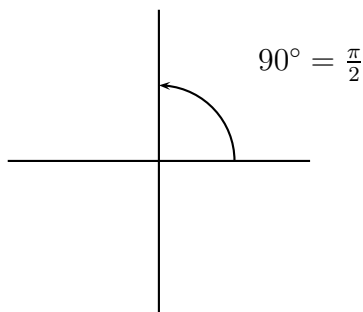

Draw the following angles in standard position.

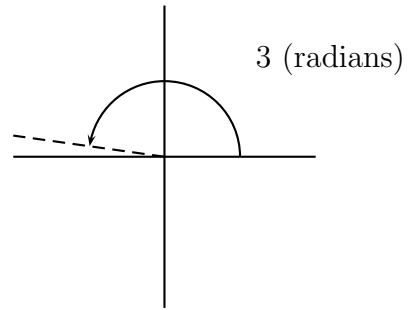
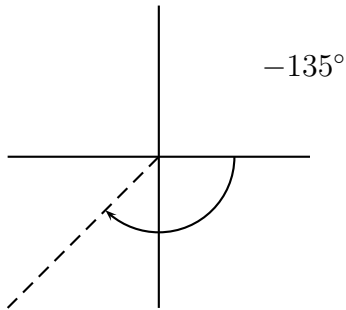
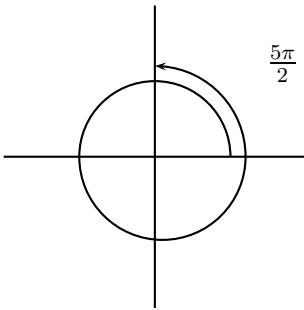

When changing from degrees to radians or vice versa just remember that degrees/360 is the same fraction of a circle as radians/2π. So if an angle is x degrees and y radians, then:

$$\frac{x^\circ}{360^\circ} = \frac{y}{2\pi}$$

Solving we have the formulas:

$$x^\circ = \frac{180^\circ}{\pi}y \quad \text{and} \quad y = \frac{\pi x^\circ}{180^\circ}$$

Example 1.4: What is 45° in radians?

$$y = \frac{\pi 45^\circ}{180^\circ} = \frac{\pi}{4}$$

Example 1.5: What is $\frac{3\pi}{2}$ in degrees?

$$x^\circ = \frac{180^\circ}{\pi} \left(\frac{3\pi}{2} \right) = 270^\circ$$

Example 1.6: Approximately what is 1 radian in degrees?

Solution:

$$x^\circ = \frac{180^\circ}{\pi} 1 \approx 57.3^\circ$$

1.1.1 Co-terminal Angles

Definition: Two angles are said to be **co-terminal** if, when in standard position, they have the same terminal side.

Example 1.7: The three angles below are **co-terminal**.

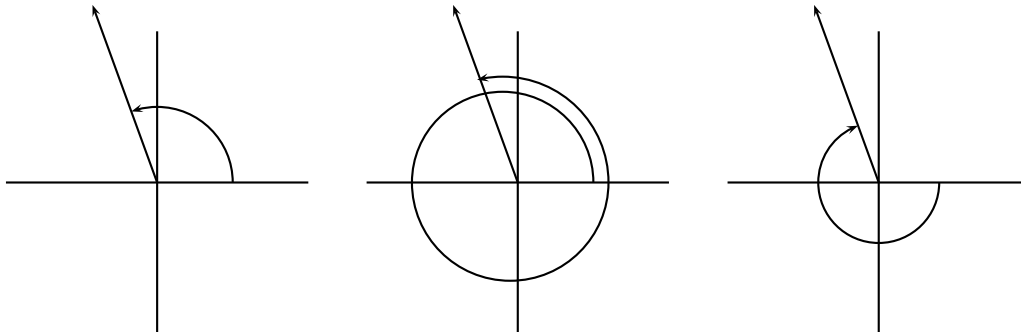

If measured in degrees then the angles θ and ϕ are co-terminal if and only if:

$$\theta = \phi + 360^\circ n \quad \text{for some integer } n.$$

If measured in radians then the angles θ and ϕ are co-terminal if and only if:

$$\theta = \phi + 2\pi n \quad \text{for some integer } n.$$

Example 1.8: Write three positive angles and three negative angles co-terminal to 110° .

Solution:

$$\begin{aligned} n = 0 : & 110^\circ + 0^\circ = 110^\circ \\ n = 1 : & 110^\circ + 360^\circ = 470^\circ \\ n = 2 : & 110^\circ + 2 \cdot 360^\circ = 830^\circ \\ n = -1 : & 110^\circ - 360^\circ = -250^\circ \\ n = -2 : & 110^\circ - 2 \cdot 360^\circ = -610^\circ \\ n = -3 : & 110^\circ - 3 \cdot 360^\circ = -970^\circ \end{aligned}$$

Example 1.9: Write three positive angles and three negative angles co-terminal to $\frac{7\pi}{6}$.

Solution:

$$n = 0 : \frac{7\pi}{6} + 0 = \frac{7\pi}{6}$$

$$n = 1 : \frac{7\pi}{6} + \frac{12\pi}{6} = \frac{19\pi}{6}$$

$$n = 2 : \frac{7\pi}{6} + \frac{24\pi}{6} = \frac{31\pi}{6}$$

$$n = -1 : \frac{7\pi}{6} - \frac{12\pi}{6} = -\frac{5\pi}{6}$$

$$n = -2 : \frac{7\pi}{6} - \frac{24\pi}{6} = -\frac{17\pi}{6}$$

$$n = -3 : \frac{7\pi}{6} - \frac{36\pi}{6} = -\frac{29\pi}{6}$$

Notice we can also tell if two given angles are co-terminal since we know ϕ and θ are co-terminal if and only if $\phi - \theta = 360^\circ n$ (or $2\pi n$ if in radians).

Example 1.10: Determine which, if any, of the angles below are co-terminal.

$$220^\circ, 600^\circ, -500^\circ$$

Solution:

$220^\circ - 600^\circ = -380^\circ \neq 360^\circ n$ so 220° and 600° are **not** co-terminal.

What about the others?

$$220^\circ - (-500^\circ) = 720^\circ = 2(360^\circ)$$

So, yes, 220° is coterminal to -500° .

$$600^\circ - (-500^\circ) = 1100^\circ \neq n(360^\circ)$$

So, no, 600° is not coterminal to -500° .

Homework 1.1

- Draw the following angles (the **turnings**, not just the terminal side).
 - $\frac{3\pi}{2}$
 - $\frac{4\pi}{3}$
 - $\frac{5\pi}{4}$
 - $\frac{13\pi}{3}$
 - $-\frac{\pi}{8}$
 - $\frac{3\pi}{8}$
 - $\frac{13\pi}{8}$
 - $\frac{23\pi}{8}$
- Convert the following angles measured in degrees to angles measured in radians.
 - 135°
 - 400°
 - -250°
- Convert the following angles measured in radians to angles measured in degrees.
 - $\frac{3\pi}{8}$
 - $\frac{25\pi}{6}$
 - -16 (approximately)
- The measure of an angle in standard position is given. Find two positive and two negative angles that are co-terminal to the given angle.
 - 50°
 - $\frac{3\pi}{4}$
 - $-\frac{\pi}{6}$
- Determine whether the angles are co-terminal.
 - 70° and 430° .
 - -30° and 330° .
 - $\frac{17\pi}{6}$ and $\frac{5\pi}{6}$.
 - $\frac{32\pi}{3}$ and $\frac{11\pi}{3}$.
 - 155° and 875° .

Further practice: Page 480 (sec 6.1) #1-40

Solutions:

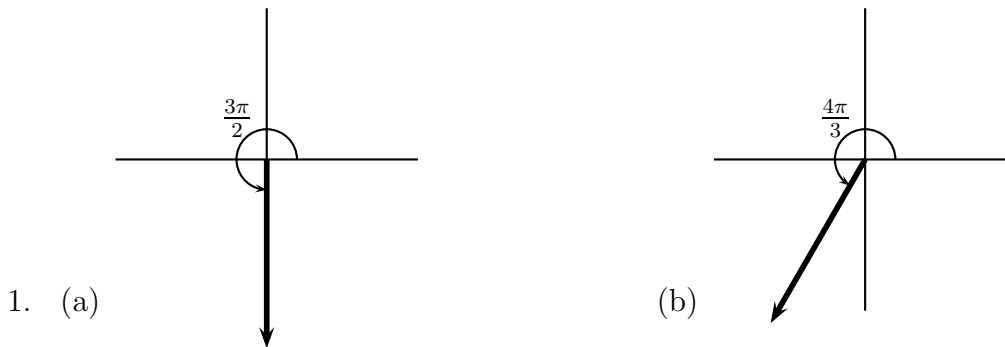

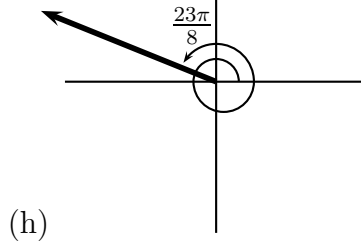
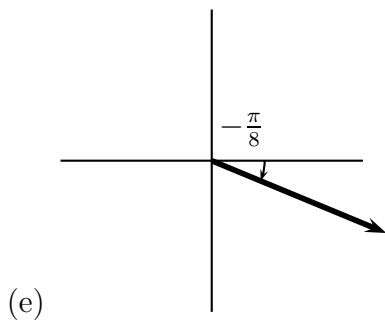
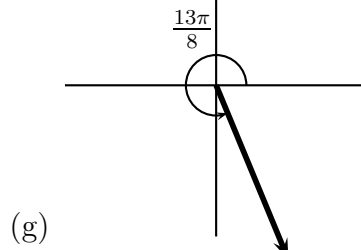
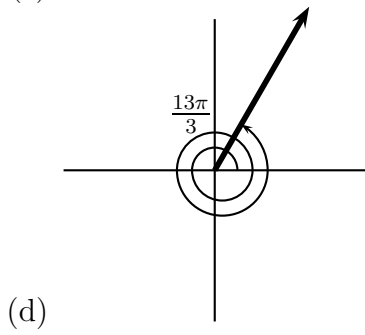
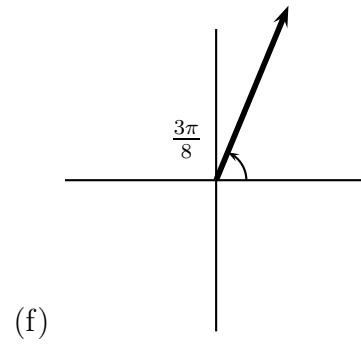
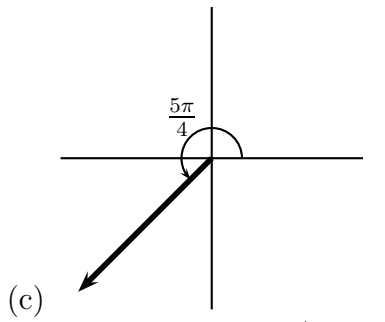

2. (a) $\frac{3\pi}{4}$ (b) $\frac{20\pi}{9}$ (c) $-\frac{25\pi}{18}$

3. (a) 67.5° (b) 750° (c) -916.7°

4. (a) $410^\circ, 770^\circ, -310^\circ, -670^\circ$ (b) $\frac{11\pi}{4}, \frac{19\pi}{4}, \frac{-5\pi}{4}, \frac{-13\pi}{4}$ (c) $\frac{11\pi}{6}, \frac{23\pi}{6}, \frac{-13\pi}{6}, \frac{-19\pi}{6}$

5. (a) $70^\circ - 430^\circ = -360^\circ$ coterminal (b) $70^\circ - 430^\circ = -360^\circ$ coterminal

(c) $\frac{17\pi}{6} - \frac{5\pi}{6} = \frac{12\pi}{6} = 2\pi$ coterminal (d) $\frac{32\pi}{3} - \frac{11\pi}{3} = \frac{21\pi}{3} = 7\pi$ Not coterminal

(e) $155^\circ - 875^\circ = (-2)360^\circ$ coterminal

1.2 Radian Formulas

Degrees are the oldest way to measure angles, but in many ways radians are the better way to measure angles. Many formulas from calculus assume that all angles are given in radians (and this is important).

The formulas below also assume angles are given in radians.

1.2.1 Arc-length

In general the **arc-length** is the distance along a curving path. In this class we only consider the distance along a circular path.

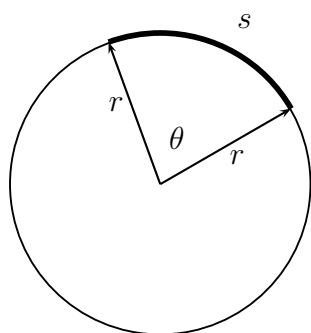

If we consider the fraction of the circle swept out by the angle θ and recall the circumference of a circle is $2\pi r$, then we have

$$\frac{\theta}{2\pi} = \frac{s}{2\pi r}$$

which we solve to get the **Arc-length Formula**.

$$s = \theta r \quad (\theta \text{ in radians})$$

Example 1.11: Find the length of the arc on a circle of radius 18 cm subtended by the an angle of 100° .

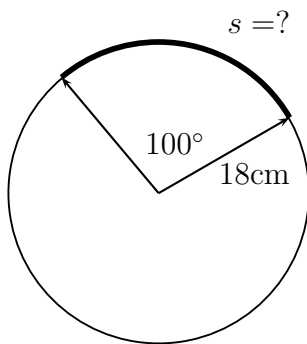

First change 100° to radians:

$$\theta = \frac{\pi}{180^\circ} 100^\circ = \frac{5\pi}{9}$$

Then find s :

$$s = \frac{5\pi}{9} \cdot 18 = 10\pi$$

Example 1.12: The distance from the Earth to the Sun is approximately one hundred fifty million kilometers (1.5×10^8 km). Assuming a circular orbit, how far does the Earth move in four months?

$$\frac{\theta}{2\pi} = \frac{4 \text{ months}}{12 \text{ months}} = \frac{1}{3} \quad \Rightarrow \quad \theta = \frac{2\pi}{3}$$

$$s = \frac{2\pi}{3} \cdot 1.5 \times 10^8 \approx 3.14 \times 10^8 \text{ km}$$

1.2.2 Angular Speed

Everyone remembers the old formula for speed:

$$\text{speed} = \frac{\text{distance}}{\text{time}}$$

When we talk about circular motion there are two kinds of speed: **linear speed** (denoted v) and **angular speed** (denoted ω).

$$\text{linear speed} = v = \frac{\text{arc length}}{\text{time}}$$

$$\text{angular speed} = \omega = \frac{\text{angle}}{\text{time}}$$

If we take the arc-length formula and divide both sides by time,

$$s = \theta r \quad \Rightarrow \quad \frac{s}{t} = \frac{\theta}{t} r$$

we get the **Angular Speed Formula**

$$\boxed{v = \omega r \quad \left(\omega \text{ in } \frac{\text{radians}}{\text{time}} \right)}$$

Example 1.13: A merry-go-round is ten meters across and spinning at a rate of 1.5 rpm (rotations per minute). What is the angular speed (in radians/minute) of a child on a horse at the edge of the merry-go-round? What is the linear speed (in kilometers/hour) of the child?

Solution: The angular speed is 1.5 rpm. To put it into the appropriate units:

$$\omega = 1.5 \frac{\text{rotations}}{\text{minute}} \cdot \frac{2\pi \text{ radians}}{\text{rotation}} = 3\pi \frac{\text{radians}}{\text{minute}}$$

The linear speed simply uses the Angular Speed Formula:

$$v = \omega r = \frac{3\pi}{\text{minute}} \cdot 5 \text{ meters} = 15\pi \frac{\text{meters}}{\text{minute}}$$

Note ‘radians’ is a dimensionless unit and so may be dropped. We need only change linear speed to the appropriate units.

$$v = 15\pi \frac{\text{meters}}{\text{minute}} \cdot \frac{\text{kilometer}}{1000 \text{ meters}} \cdot \frac{60 \text{ minutes}}{\text{hour}} \approx 2.83 \frac{\text{kilometers}}{\text{hour}}$$

Example 1.14: What is the linear speed of the Earth (in km/hr)?
(*Hint:* Use example 1.12)

First the angular speed in radians/hour:

$$\omega = \frac{2\pi \text{ radians}}{1 \text{ year}} \cdot \frac{1 \text{ year}}{365.25 \text{ day}} \cdot \frac{1 \text{ day}}{24 \text{ hour}} \approx 0.0007168 \frac{\text{radians}}{\text{hour}}$$

And so the linear speed is:

$$v \approx 0.0007168 \cdot 1.5 \times 10^8 \approx 107515 \text{ km/h}$$

1.2.3 Sector Area

As well as discussing the length of an arc subtended by an angle, we may also talk about the area of the wedge subtended by an angle. This is called the **Sector Area** (denoted A).

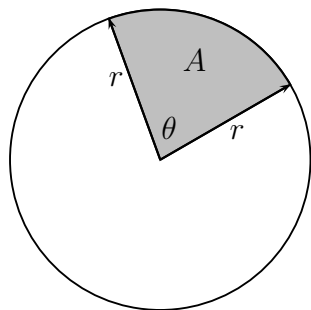

If we consider the fraction of the circle swept out by the angle θ and recall the area of a circle is πr^2 , then we have

$$\frac{\theta}{2\pi} = \frac{A}{\pi r^2}$$

which we solve to get the **Sector Area Formula**.

$$A = \frac{1}{2}\theta r^2 \quad (\theta \text{ in radians})$$

Example 1.15: A wedge-shaped slice of pizza has an area of 60cm^2 . The end of the slice makes an angle of 35° . What was the diameter of the pizza from which the slice was taken?

$$\theta = \frac{\pi}{180^\circ} \cdot 35^\circ = \frac{7\pi}{36}$$

$$60 = \frac{1}{2} \left(\frac{7\pi}{36} \right) r^2 \quad \Rightarrow \quad r = \sqrt{\frac{2 \cdot 60 \cdot 36}{7\pi}} \approx 14 \text{ cm}$$

So the diameter is 28 cm.

Homework 1.2

1. Find the length of the arc s in the figure.

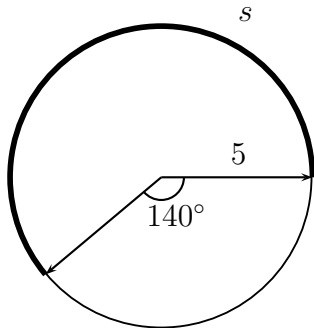

2. Find the angle θ in the figure (in degrees).

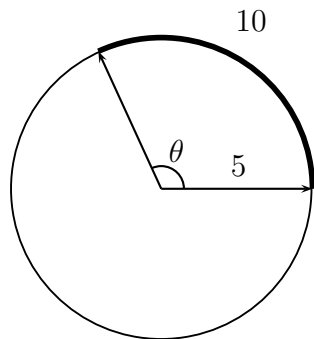

3. Find the radius r of the circle in the figure.

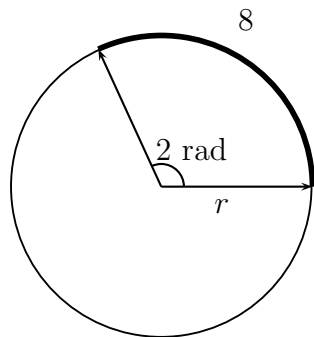

4. Pittsburgh, PA and Miami, FL lie approximately on the same meridian (they have the same longitude). Pittsburgh has a latitude of 40.5° N and Miami 25.5° N . (The radius of the Earth is 3960 miles.) Find the distance between the two cities.

5. The Greek mathematician Eratosthenes (ca. 276-195 B.C.E) measured the radius of the Earth from the following observations. He noticed that on a certain day at noon the sun shown directly down a deep well in Syene (modern Aswan, Egypt). At the same time 500 miles north on the same meridian in Alexandria the sun's rays shown at an angle of 7.2° with the zenith (as measured by the shadow of a vertical stick). Use this information (and the figure) to calculate the radius of the Earth.

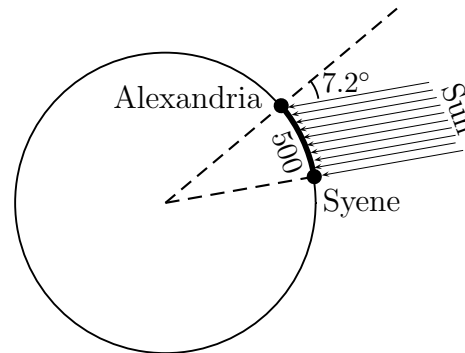

6. Find the area of the sector shown in the figure below.

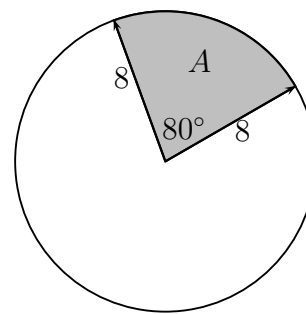

7. A ceiling fan with 16 inch blades rotates at 45 rpm.
- What is the angular speed of the fan in rad/min?
 - What is the linear speed of the tips of the blades (in inches per second)?

8. The Earth rotates about its axis once every 23 hours, 56 minutes, and 4 seconds. The radius of the Earth is 3960 miles.

What is the linear speed of a point on the Earth's equator (in miles per hour)?

9. The sprockets and chain of a bicycle are shown in the figure. The pedal sprocket has a radius of 5 inches, the wheel sprocket a radius of 2 inches, and the wheel a radius of 13 inches. The cyclist pedals at 40 rpm.

- (a) Find the linear speed of the chain.

- (b) Find the angular speed of the wheel sprocket.
 (c) Find the speed of the bicycle (in miles per hour).

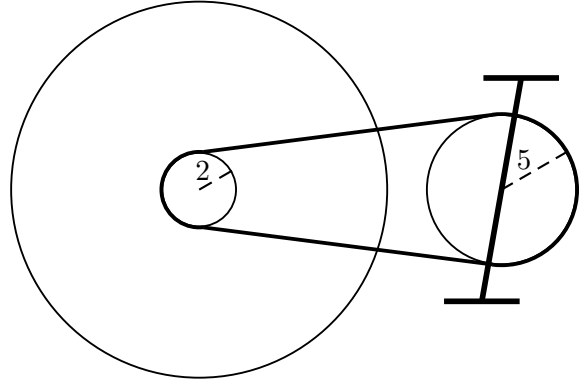

Further practice: Page 481 (sec 6.1) #41-70

Solutions

1. $\theta = 220^\circ$, $s \approx 19.2$
2. $\theta = 2$ rads or $\theta \approx 114.6^\circ$
3. $r = 4$
4. Let s be the distance, then $s = 3960(40.5^\circ - 25.5^\circ) \left(\frac{\pi}{180^\circ}\right) \approx 1036.7$ miles
5. $r \approx 3979$ miles
6. $A \approx 44.68$
7. (a) $90\pi \frac{\text{rad}}{\text{min}}$, (b) $v = 8(90\pi) \frac{\text{in}}{\text{min}} \approx 37.7 \frac{\text{in}}{\text{sec}}$
8. $v \approx 3960 \left(\frac{2\pi}{23.9344}\right) \approx 1039.6$ mph
9. (a) The velocity of the chain equals the linear velocity of the pedal sprocket:
 $v_{\text{chain}} = v_{\text{ps}} = 400\pi \frac{\text{in}}{\text{min}}$
 (b) The velocity of the chain also equals the linear velocity of the wheel sprocket:
 $\omega_{\text{ws}} = \frac{v_{\text{chain}}}{r} = 200\pi \frac{\text{rad}}{\text{min}}$
 (c) The angular speed of the wheel sprocket equals the angular speed of the wheel, so
 $v_{\text{bike}} = (13)(200\pi) \approx 8168.14 \frac{\text{in}}{\text{min}} = 7.7$ mph

Chapter 2

Trigonometric Functions

Now that we understand about angles we move on to the most important subject in this class—functions whose domain consists of angles. That is, functions which take an angle and return a real number. The ones we care about are called the **trigonometric functions**, and there are six of them: sine, cosine, tangent, cotangent, secant, and cosecant. In the next sections we will define these functions and discuss their properties.

2.1 Acute Angles

The trigonometric functions are defined for almost all angles from minus infinity to plus infinity. However their values are particularly easy to understand when applied to **acute angles** (angles between 0° and 90°). Acute angles are characterized by being an interior angle of a right triangle.

Say θ is an acute angle. Then θ is an interior angle in a right triangle, and we may define the six trigonometric functions as follows:

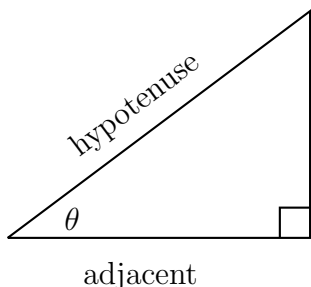

$$\sin \theta = \frac{\text{opposite}}{\text{hypotenuse}}$$

$$\sec \theta = \frac{\text{hypotenuse}}{\text{adjacent}}$$

$$\cos \theta = \frac{\text{adjacent}}{\text{hypotenuse}}$$

$$\csc \theta = \frac{\text{hypotenuse}}{\text{opposite}}$$

$$\tan \theta = \frac{\text{opposite}}{\text{adjacent}}$$

$$\cot \theta = \frac{\text{adjacent}}{\text{opposite}}$$

Example 2.1:

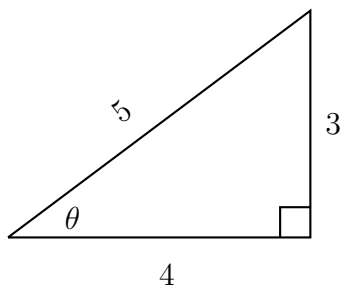

$$\sin \theta = \frac{3}{5}$$

$$\sec \theta = \frac{5}{4}$$

$$\cos \theta = \frac{4}{5}$$

$$\csc \theta = \frac{5}{3}$$

$$\tan \theta = \frac{3}{4}$$

$$\cot \theta = \frac{4}{3}$$

Some people remember the first three definitions with the acronym: **SOHCAHTOA** for “Sine is Opposite over Hypotenuse, Cosine is Adjacent over Hypotenuse, and Tangent is Opposite over Adjacent.

You might fear that this definition of the trigonometric functions will depend on the size of the triangle. It does not. Below is a triangle *similar* to the triangle in example 2.1.

Example 2.2:

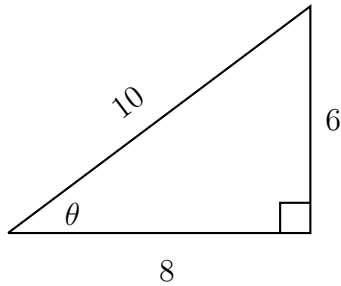

Note that still

$$\cos \theta = \frac{8}{10} = \frac{4}{5}$$

$$\tan \theta = \frac{6}{8} = \frac{3}{4}$$

etc.

We now introduce two special right triangles whose angles and sides are known exactly. The $45^\circ - 45^\circ - 90^\circ$ **Triangle**:

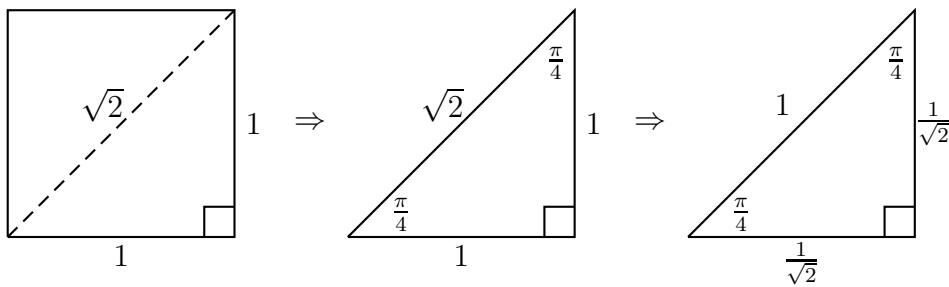

The $30^\circ - 60^\circ - 90^\circ$ **Triangle**:

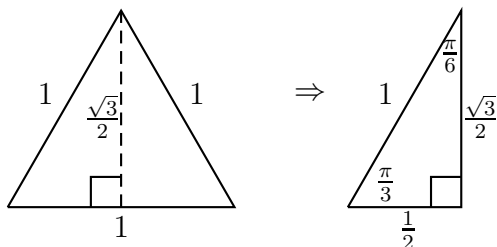

Example 2.3: Evaluate the trig functions:

$$\sin(60^\circ) = \frac{\sqrt{3}/2}{1} = \frac{\sqrt{3}}{2}$$

$$\tan\left(\frac{\pi}{3}\right) = \frac{\sqrt{3}/2}{1/2} = \sqrt{3}$$

$$\cos\left(\frac{\pi}{4}\right) = \frac{1}{\sqrt{2}}$$

$$\sec\left(\frac{\pi}{6}\right) = \frac{1}{\sqrt{3}/2} = \frac{2}{\sqrt{3}}$$

Using the values of the trigonometric functions for $\pi/6, \pi/4$, and $\pi/3$, we may solve for the sides of any triangle which has these one of these angles in it (if one side is known).

Example 2.4: Use the exact values of appropriate trig functions to find the sides b and h in the triangle below.

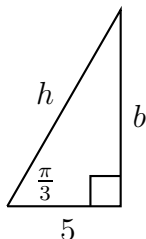

Solution: We want to know b , the side **opposite** to $\pi/3$, and we already know that the side **adjacent** to $\pi/3$ is 5, so we use the **tangent** (opposite over adjacent). Thus,

$$\begin{aligned}\tan\left(\frac{\pi}{3}\right) &= \frac{b}{5} \\ \sqrt{3} &= \frac{b}{5} \\ \Rightarrow b &= 5\sqrt{3}\end{aligned}$$

To find $h \dots ?$

Similarly we now want to know the **hypotenuse**, so we use **cosine**.

$$\begin{aligned}\cos\left(\frac{\pi}{3}\right) &= \frac{5}{h} \\ \frac{1}{2} &= \frac{5}{h} \\ \Rightarrow h &= 10\end{aligned}$$

Example 2.5: A 15 foot long ladder is leaned against a wall so that the ladder makes a 60° angle with the floor. Use a trigonometric function to determine how high up the wall the ladder reaches. (Be sure to draw a picture.)

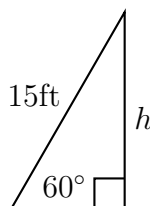

Solution:

$$\begin{aligned}\sin(60^\circ) &= \frac{h}{15} \\ \frac{\sqrt{3}}{2} &= \frac{h}{15} \\ \Rightarrow h &= \frac{15\sqrt{3}}{2} \approx 13 \text{ ft}\end{aligned}$$

For angles other than 30° , 45° , or 60° we cannot (usually) find an exact value for the trigonometric functions. However using a calculator, we may approximate the sides of any right triangle where an angle and one of the sides is known.

Example 2.6: Use a trig function and your calculator to approximate the value of the unknown sides.

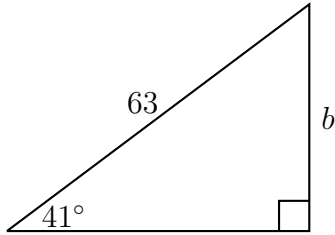

We want the **adjacent**, a , and we know the **hypotenuse**, 63.

$$\cos(41^\circ) = \frac{a}{63}$$

$$0.7547 \approx \frac{a}{63}$$

$$\Rightarrow a \approx 63(0.7547) \approx 47.55$$

To find b ...?

$$\sin(41^\circ) = \frac{b}{63}$$

$$0.6561 \approx \frac{b}{63}$$

$$\Rightarrow b \approx 63(0.6561) \approx 41.33$$

Example 2.7: When the sun is 50° above the horizon a tree casts a shadow that is 20 meters long. Use a trigonometric function and your calculator to estimate the height of the tree. (Be sure to draw a picture.)

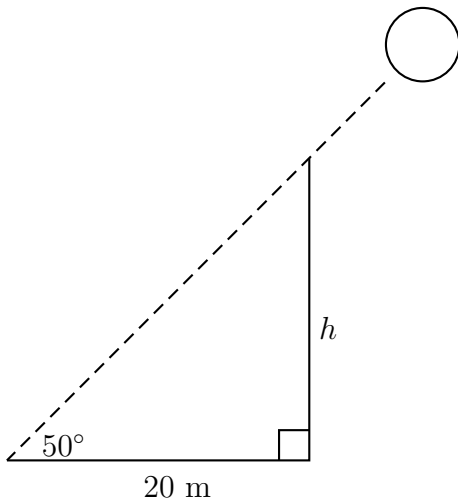

$$\tan(50^\circ) = \frac{h}{20}$$

$$1.192 \approx \frac{h}{20}$$

$$\Rightarrow h \approx 20(1.192) \approx 23.8 \text{ meters}$$

Homework 2.1

1. Use a trig function to find the exact value of the unknown sides.

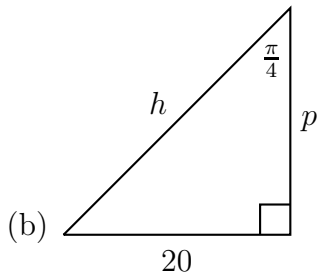
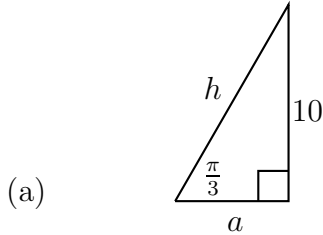

2. Use a trig function and your calculator to approximate the value of the unknown sides.

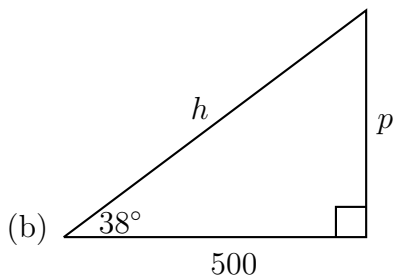
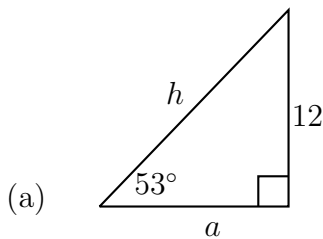

3. From the top of a 100 meter high lighthouse the angle of depression to a ship in the ocean is 28° . How far is the ship from the base of the lighthouse? (Be sure to draw a picture.)

4. A man is lying on the ground, flying a kite. He holds the end of the kite string at ground level, and estimates the angle of elevation to be 40° . If the string is 200 meters long, how high is the kite?

5. A flagpole is 50 meters from a school building. From a window in the school the angle of elevation to the top of the flagpole is 35° , while the angle of depression to the base of the flagpole is 25° . How tall is the flagpole?

6. The method of *parallax* can be used to calculate the distance to near-by stars. A not too distant star will apparently move (slightly) as the Earth goes around the Sun. For instance over a six month period the binary star α -Centauri appears to shift $.000422^\circ$ in the sky.

Given that the Sun is about 1.5×10^8 kilometers from the Earth, how far is α -Centauri from the Sun?

(See figure)

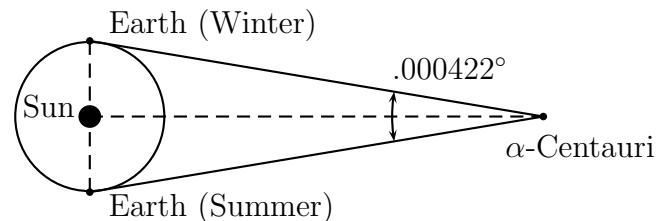

Further practice: Page 489 (sec 6.2) #1-53

Solutions

1. (a) $h = \frac{20}{\sqrt{3}} \approx 11.55$ and $a = \frac{10}{\sqrt{3}} \approx 5.77$, (b) $p = 20$ and $h = \sqrt{800} = 20\sqrt{2} \approx 28.28$
2. (a) $h \approx 15$ and $a \approx 9$
3. The distance is about 188 meters. Remember that the angle of depression is measured downward from the horizontal.
4. ≈ 129 meters
5. $h \approx 58.3$ meters. Hint: Use two right triangles.
6. $\approx 4.073 \times 10^{13}$ kilometers.

2.2 Unit Circle

The definition of the trigonometric functions for general angles (not just acute angles) involves the **unit circle**. What is the unit circle, you say? It's the circle, centered at the origin, with radius one.

Alternatively it's the set of all points (x, y) which satisfy the equation: $x^2 + y^2 = 1$.

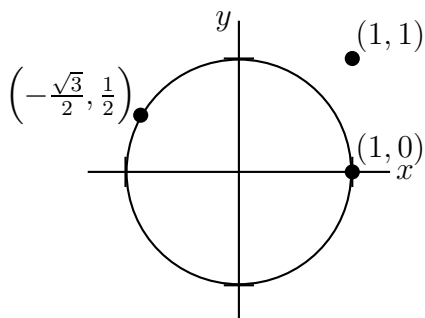

$$1^2 + 0^2 = 1$$

$$\left(-\frac{\sqrt{3}}{2}\right)^2 + \left(\frac{1}{2}\right)^2 = 1$$

$$1^2 + 1^2 = 2 \neq 1$$

We now define sine and cosine for any angle. The other four trigonometric functions will be defined in terms of sine and cosine.

Draw the angle θ in standard position. Consider the point p where the terminal side of θ crossed the unit circle.

The x coordinate of p is $\cos \theta$.

The y coordinate of p is $\sin \theta$.

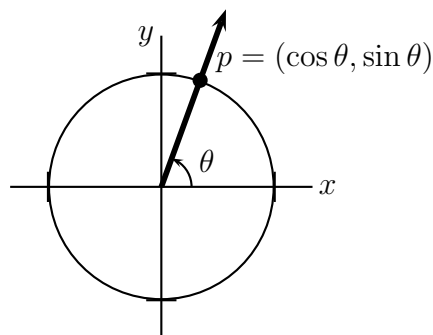

Example 2.8: Find the cosine and sine of 90° .

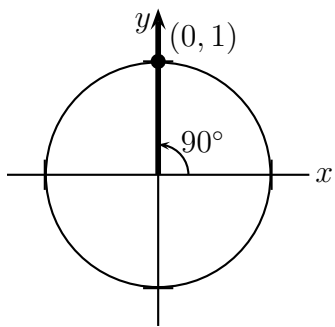

$$p = (0, 1)$$

$$\cos(90^\circ) = 0$$

$$\sin(90^\circ) = 1$$

Example 2.9: Draw the angle and find the cosine and sine of -180° .

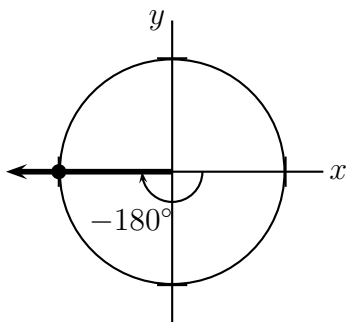

$$p = (-1, 0)$$

$$\cos(-180^\circ) = -1$$

$$\sin(-180^\circ) = 0$$

Example 2.10: Draw the angle and find the cosine and sine of $\frac{7\pi}{2}$.

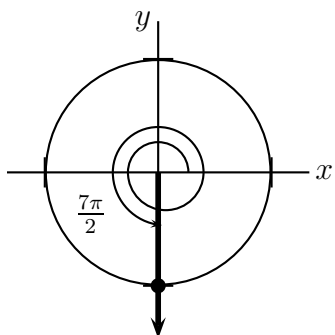

$$p = (0, -1)$$

$$\cos\left(\frac{7\pi}{2}\right) = 0$$

$$\sin\left(\frac{7\pi}{2}\right) = -1$$

Now that we basically understand sine and cosine, let's ask some basic questions. What is the **domain** of sine (and cosine)? The definition makes sense for any angle, so

$$\text{Domain}(\sin) = \text{Domain}(\cos) = (-\infty, \infty)$$

What is the **range** of sine (and cosine)?

The output for either function is as big as +1 and as small as -1 with all numbers in between, so

$$\text{Range}(\sin) = \text{Range}(\cos) = [-1, 1]$$

Example 2.11: Say θ is an angle in the second quadrant with the properties:

$$\cos \theta = -\frac{3}{5} \text{ and } \sin \theta = \frac{4}{5}.$$

What quadrant is $\theta + \pi$ in? What is the cosine and sine of $\theta + \pi$?

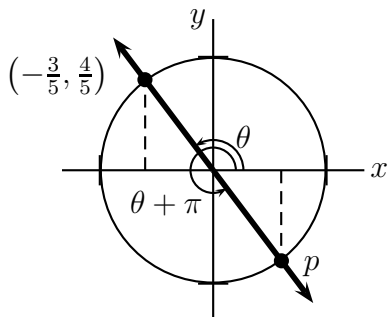

$\theta + \pi$ is in quadrant IV.

The two triangles are congruent.

Therefore,

$$p = \left(\frac{3}{5}, -\frac{4}{5}\right)$$

$$\cos(\theta + \pi) = \frac{3}{5}$$

$$\sin(\theta + \pi) = -\frac{4}{5}$$

Example 2.12: Say θ is as in example 2.11. What quadrant is $-\theta$ in? Draw the angle and find the cosine and sine of $-\theta$.

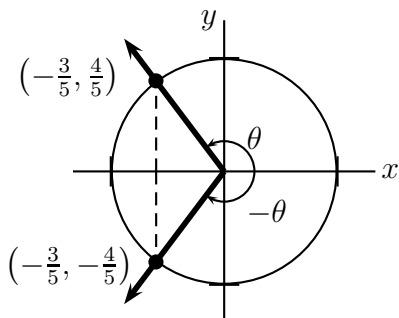

$-\theta$ is in Quad III

$$p = \left(-\frac{3}{5}, -\frac{4}{5}\right)$$

$$\cos(-\theta) = -\frac{3}{5}$$

$$\sin(-\theta) = -\frac{4}{5}$$

There are a couple of important things to be learned from examples 2.11 and 2.12. First, cosine is positive when the x coordinate is positive—that is in quadrants I and IV. Sine is positive when the y coordinate is positive—in quadrants I and II. Tangent will be defined to be the sine divided by the cosine. Therefore tangent is positive when both sine and cosine are positive or both negative—quadrants I and III. This important information is encapsulated in the following diagram and mnemonic.

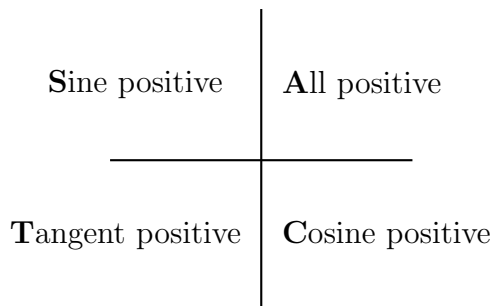

“All Students Take Calculus”

Second, $\cos(-\theta) = \cos(\theta)$ while $\sin(-\theta) = -\sin(\theta)$. This means cosine is an **even** function, while sine is an **odd** function. We will have more to say about this in the next section.

We now consider the cosine and sine of certain special angles.

Example 2.13: Use one of the special triangles to find the cosine and sine of $\frac{3\pi}{4}$.

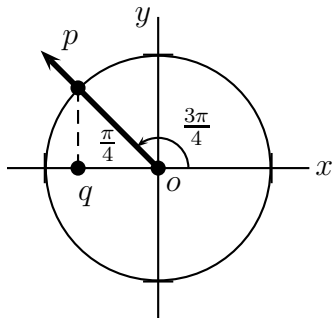

The triangle pqo is $45^\circ - 45^\circ - 90^\circ$. Therefore,

$$p = \left(-\frac{1}{\sqrt{2}}, \frac{1}{\sqrt{2}}\right)$$

$$\cos\left(\frac{3\pi}{4}\right) = -\frac{1}{\sqrt{2}}$$

$$\sin\left(\frac{3\pi}{4}\right) = \frac{1}{\sqrt{2}}$$

Example 2.14: Find the quadrant and draw the angle -60° .
 Draw the appropriate special triangle and find the cosine and sine of -60° .

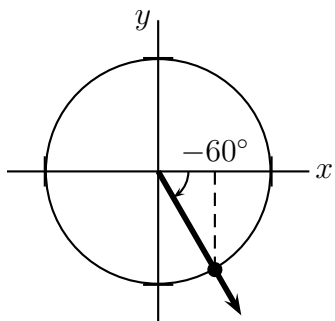

-60° is in Quad IV.

$$p = \left(\frac{1}{2}, -\frac{\sqrt{3}}{2}\right)$$

$$\cos(-60^\circ) = \frac{1}{2}$$

$$\sin(-60^\circ) = -\frac{\sqrt{3}}{2}$$

Example 2.15: Find the quadrant and draw the angle $\frac{7\pi}{6}$.
 Draw the appropriate special triangle and find the cosine and sine of $\frac{7\pi}{6}$.

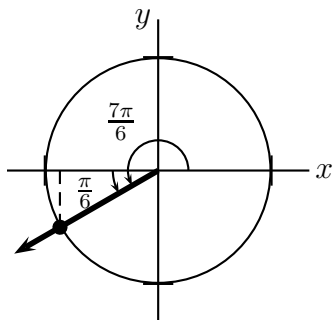

$\frac{7\pi}{6}$ is in Quad III.

$$p = \left(-\frac{\sqrt{3}}{2}, -\frac{1}{2}\right)$$

$$\cos\left(\frac{7\pi}{6}\right) = -\frac{\sqrt{3}}{2}$$

$$\sin\left(\frac{7\pi}{6}\right) = -\frac{1}{2}$$

2.2.1 Reference Angle

Definition: *The reference angle to an angle, θ in standard position, is the smallest positive angle between the terminal side of θ and the x-axis.*

From example 2.13 we see that reference angle for $\frac{3\pi}{4}$ is $\frac{\pi}{4}$.

From example 2.14 we see that reference angle for -60° is $+60^\circ$.

From example 2.15 we see that reference angle for $\frac{7\pi}{6}$ is $\frac{\pi}{6}$.

Note the reference angle is always between 0° and 90° .

Example 2.16: What is the reference angle for $\frac{5\pi}{6}$? $\frac{\pi}{6}$

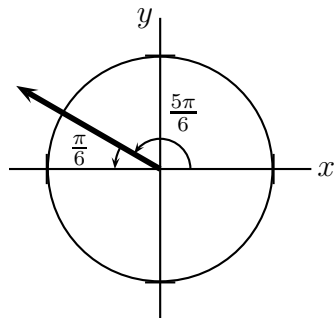

Example 2.17: What is the reference angle for $\frac{17\pi}{3}$? $\frac{\pi}{3}$

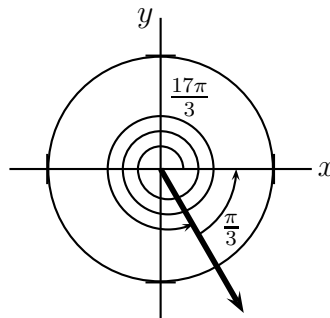

The reason we care about the reference angle is that the cosine (or sine) of any angle is plus or minus the cosine (or sine) of its reference angle. You figure out the plus or minus based on the quadrant.

Example 2.18: Find the cosine and sine of $\frac{5\pi}{6}$.

Solution: $\frac{5\pi}{6}$ is in quadrant II.

By example 2.16 the reference angle for $\frac{5\pi}{6}$ is $\frac{\pi}{6}$.

Thus,

$$\cos\left(\frac{5\pi}{6}\right) = \pm \cos\left(\frac{\pi}{6}\right) = -\frac{\sqrt{3}}{2}$$

(since cosine is negative in quadrant II).

$$\sin\left(\frac{5\pi}{6}\right) = \pm \sin\left(\frac{\pi}{6}\right) = +\frac{1}{2}$$

(since sine is positive in quadrant II).

Example 2.19: Find the cosine and sine of $\frac{17\pi}{3}$.
 $\frac{17\pi}{3}$ is in quadrant IV, so

$$\cos\left(\frac{17\pi}{3}\right) = \cos\left(\frac{5\pi}{3}\right) = \pm \cos\left(\frac{\pi}{3}\right) = +\frac{1}{2}$$

$$\sin\left(\frac{17\pi}{3}\right) = \sin\left(\frac{5\pi}{3}\right) = \pm \sin\left(\frac{\pi}{3}\right) = -\frac{\sqrt{3}}{2}$$

Notice on example 2.19 the very handy fact that, since sine and cosine only depend on the terminal side, **co-terminal angles have the same sine and cosine.**

Thus, $\cos\left(\frac{17\pi}{3}\right) = \cos\left(\frac{5\pi}{3}\right)$ since $\frac{17\pi}{3}$ and $\frac{5\pi}{3}$ are co-terminal angles.

2.2.2 Definition of the Other Trig Functions

The other trigonometric functions are defined in terms of cosine and sine, so once you know these functions you know all six trig functions.

$$\tan \theta = \frac{\sin \theta}{\cos \theta} \qquad \sec \theta = \frac{1}{\cos \theta}$$

$$\cot \theta = \frac{\cos \theta}{\sin \theta} \qquad \csc \theta = \frac{1}{\sin \theta}$$

Example 2.20: Find the tangent of $\frac{3\pi}{4}$.

Solution:

$$\tan \left(\frac{3\pi}{4} \right) = \frac{\sin \frac{3\pi}{4}}{\cos \frac{3\pi}{4}} = \frac{1/\sqrt{2}}{-1/\sqrt{2}} = -1$$

Example 2.21: Find the secant of $\frac{5\pi}{6}$.

$$\sec \left(\frac{5\pi}{6} \right) = \frac{1}{\cos \frac{5\pi}{6}} = \frac{1}{-\sqrt{3}/2} = -\frac{2}{\sqrt{3}}$$

Example 2.22: Find the cotangent of $\frac{7\pi}{6}$.

$$\cot \left(\frac{7\pi}{6} \right) = \frac{\cos \frac{7\pi}{6}}{\sin \frac{7\pi}{6}} = \frac{-\sqrt{3}/2}{-1/2} = \sqrt{3}$$

2.2.3 Pythagorean Identities

Definition: *Identities are equations that are satisfied by any legal value of the variable.*

We'll discuss identities in-depth in section 3.1, but for now we only consider three important identities.

Recall that the cosine and sine are the x and y coordinates of a point on the unit circle.

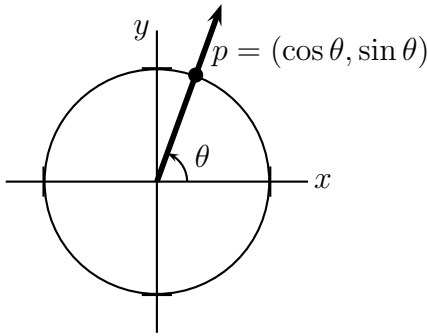

The equation of the unit circle is

$$x^2 + y^2 = 1$$

Substituting $x = \cos \theta$ and $y = \sin \theta$,

$$\boxed{\cos^2 \theta + \sin^2 \theta = 1}$$

This is the first Pythagorean Identity.

Notation: $(\sin \theta)^2$ is usually written without the parentheses as $\sin^2 \theta$. This can be done for any trig function.

The second and third Pythagorean Identities are found by dividing the first by $\cos^2 \theta$ or $\sin^2 \theta$.

$$\frac{\cos^2 \theta}{\cos^2 \theta} + \frac{\sin^2 \theta}{\cos^2 \theta} = \frac{1}{\cos^2 \theta}$$

gives $\boxed{1 + \tan^2 \theta = \sec^2 \theta}$

$$\frac{\cos^2 \theta}{\sin^2 \theta} + \frac{\sin^2 \theta}{\sin^2 \theta} = \frac{1}{\sin^2 \theta}$$

gives $\boxed{\cot^2 \theta + 1 = \csc^2 \theta}$

Example 2.23: Say θ is in Quadrant II, and $\sin \theta = \frac{2}{3}$.

Find the five remaining trig functions of θ .

Solution: We find $\cos \theta$ by substituting into the first Pythagorean identity.

$$\cos^2 \theta + \left(\frac{2}{3}\right)^2 = 1$$

$$\Rightarrow \cos \theta = \pm \sqrt{1 - \frac{4}{9}} = -\frac{\sqrt{5}}{3}$$

(Negative since cosine is negative in quadrant II.)

The other four we find by using their definitions:

$$\tan \theta = \frac{2/3}{-\sqrt{5}/3} = -\frac{2}{\sqrt{5}} \quad \cot \theta = \frac{-\sqrt{5}/3}{2/3} = -\frac{\sqrt{5}}{2}$$

$$\sec \theta = \frac{1}{-\sqrt{5}/3} = -\frac{3}{\sqrt{5}} \quad \csc \theta = \frac{1}{2/3} = \frac{3}{2}$$

Example 2.24: Say θ is in Quadrant II, and $\cos \theta = -\frac{5}{13}$.
Find the five remaining trig functions of θ .

We find $\sin \theta$ by substituting into the first Pythagorean identity.

$$\begin{aligned} \left(-\frac{5}{13}\right)^2 + \sin^2 \theta &= 1 \\ \Rightarrow \sin \theta &= \pm \sqrt{1 - \frac{25}{169}} = +\frac{12}{13} \end{aligned}$$

(Positive since sine is positive in quadrant II.)

The other four we find by using their definitions:

$$\begin{aligned} \tan \theta &= \frac{12/13}{-5/13} = -\frac{12}{5} & \cot \theta &= \frac{1}{-12/5} = -\frac{5}{12} \\ \sec \theta &= \frac{1}{-5/13} = -\frac{13}{5} & \csc \theta &= \frac{1}{12/13} = \frac{13}{12} \end{aligned}$$

Example 2.25: Say θ is in Quadrant III, and $\tan \theta = \frac{7}{5}$.

First find $\sec \theta$, then find the four remaining trig functions of θ .

We find $\sec \theta$ by substituting into the second Pythagorean identity.

$$\begin{aligned} \left(\frac{7}{5}\right)^2 + 1 &= \sec^2 \theta \\ \Rightarrow \sec \theta &= \pm \sqrt{1 + \frac{49}{25}} = -\frac{\sqrt{74}}{5} \end{aligned}$$

(Negative since secant is negative in quadrant III.)

The other four we find by using their definitions:

$$\begin{aligned} \cos \theta &= \frac{1}{-\frac{\sqrt{74}}{5}} = -\frac{5}{\sqrt{74}} & \cot \theta &= \frac{1}{7/5} = \frac{5}{7} \\ \sin \theta &= \cos \theta \tan \theta = -\frac{5}{\sqrt{74}} \frac{7}{5} = -\frac{7}{\sqrt{74}} & \csc \theta &= \frac{1}{-7/\sqrt{74}} = -\frac{\sqrt{74}}{7} \end{aligned}$$

Homework 2.2

(Note: These problems should be done without the use of a calculator.)

1. Say whether or not the following points are on the unit circle, and show how you know.

(a) $(\frac{3}{5}, \frac{4}{5})$ (c) $(-\frac{5}{13}, -\frac{12}{13})$

(b) $(\frac{1}{2}, \frac{1}{2})$ (d) $(\frac{\sqrt{7}}{3}, -\frac{\sqrt{2}}{3})$

2. Draw the angle on the unit circle and find the cosine and sine for each of the angles below. (See homework 1.1 problem 1)

(a) $\frac{3\pi}{2}$ (b) $\frac{4\pi}{3}$ (c) $\frac{5\pi}{4}$ (d) $\frac{13\pi}{3}$

3. Draw the angle on the unit circle and use the triangle below to find the cosine and sine for each of the angles below. (See homework 1.1 problem 1)

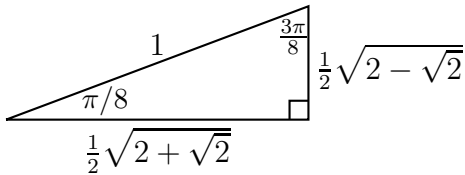

(a) $-\frac{\pi}{8}$ (b) $\frac{3\pi}{8}$ (c) $\frac{13\pi}{8}$ (d) $\frac{23\pi}{8}$

4. Find the reference angles for the angles below. (Remember reference angles are always between 0 and $\pi/2$.)

(a) $\frac{3\pi}{2}$ (c) $\frac{5\pi}{4}$ (e) $-\frac{\pi}{8}$ (g) $\frac{13\pi}{8}$

(b) $\frac{4\pi}{3}$ (d) $\frac{13\pi}{3}$ (f) $\frac{3\pi}{8}$ (h) $\frac{23\pi}{8}$

5. For θ the angle in the figure below, find the cosine and sine of the angles below.

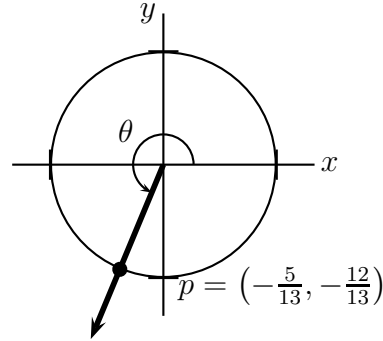

(a) $\theta + \pi$ (b) $-\theta$ (c) $\pi - \theta$

6. Find the secant and tangent of the angles below.

(a) $\frac{3\pi}{2}$ (b) $\frac{4\pi}{3}$ (c) $\frac{5\pi}{4}$ (d) $\frac{13\pi}{3}$

7. Find the cosecant and cotangent of the angles below.

(a) $-\frac{\pi}{8}$ (b) $\frac{3\pi}{8}$ (c) $\frac{13\pi}{8}$ (d) $\frac{23\pi}{8}$

8. Say θ is in Quadrant IV, and $\cos \theta = \frac{2}{5}$. Find the sine, secant, tangent, cosecant, and cotangent of θ .

9. Say θ is in Quadrant III, and $\cot \theta = \frac{3}{2}$. Find the sine, cosine, secant, cosecant, and tangent of θ .

Further practice: Page 416 (sec 5.1) #1-42, Page 426 (sec 5.2) #3-50, 61-68

Solutions

1. (a) Yes, (b) No, (c) Yes, (d) Yes

2. (a) $\cos\left(\frac{3\pi}{2}\right) = 0,$

$$\sin\left(\frac{3\pi}{2}\right) = 1$$

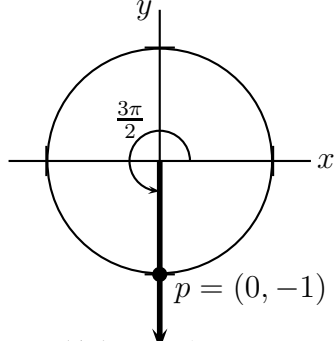

(b) $\cos\left(\frac{4\pi}{3}\right) = -\frac{1}{2},$

$$\sin\left(\frac{4\pi}{3}\right) = -\frac{\sqrt{3}}{2}$$

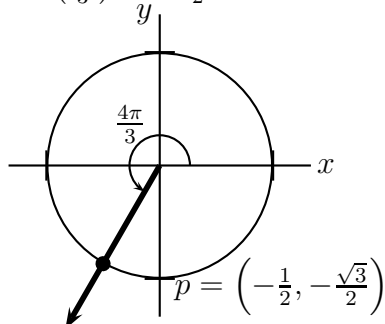

3. (a) $\cos\left(-\frac{\pi}{8}\right) = \frac{1}{2}\sqrt{2+\sqrt{2}},$

$$\sin\left(-\frac{\pi}{8}\right) = -\frac{1}{2}\sqrt{2-\sqrt{2}}$$

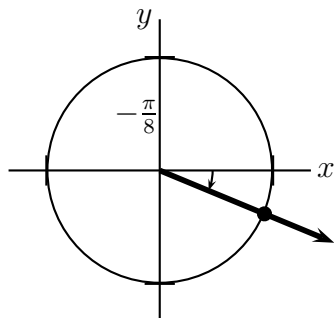

$$p = \left(\frac{1}{2}\sqrt{2+\sqrt{2}}, -\frac{1}{2}\sqrt{2-\sqrt{2}}\right)$$

(c) $\cos\left(\frac{5\pi}{4}\right) = -\frac{1}{\sqrt{2}},$

$$\sin\left(\frac{5\pi}{4}\right) = -\frac{1}{\sqrt{2}}$$

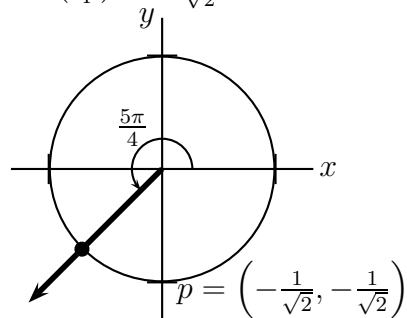

(d) $\cos\left(\frac{13\pi}{3}\right) = \frac{1}{2},$

$$\sin\left(\frac{13\pi}{3}\right) = \frac{\sqrt{3}}{2}$$

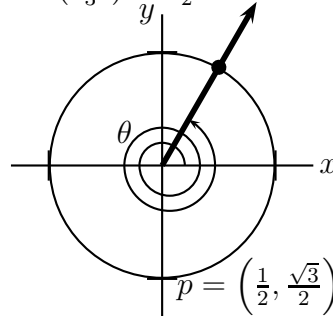

(b) $\cos\left(\frac{3\pi}{8}\right) = \frac{1}{2}\sqrt{2-\sqrt{2}},$

$$\sin\left(\frac{3\pi}{8}\right) = \frac{1}{2}\sqrt{2+\sqrt{2}}$$

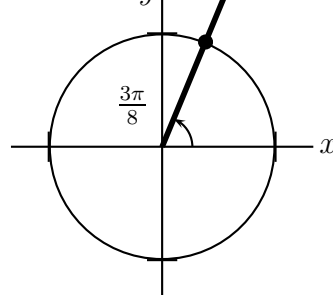

$$p = \left(\frac{1}{2}\sqrt{2-\sqrt{2}}, \frac{1}{2}\sqrt{2+\sqrt{2}}\right)$$

$$(c) \cos\left(\frac{13\pi}{8}\right) = \frac{1}{2}\sqrt{2 - \sqrt{2}},$$

$$\sin\left(\frac{13\pi}{8}\right) = -\frac{1}{2}\sqrt{2 + \sqrt{2}}$$

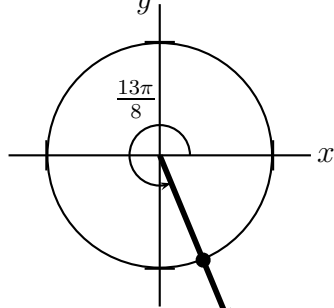

$$p = \left(\frac{1}{2}\sqrt{2 - \sqrt{2}}, -\frac{1}{2}\sqrt{2 + \sqrt{2}}\right)$$

$$(d) \cos\left(\frac{23\pi}{8}\right) = -\frac{1}{2}\sqrt{2 + \sqrt{2}},$$

$$\sin\left(\frac{23\pi}{8}\right) = \frac{1}{2}\sqrt{2 - \sqrt{2}}$$

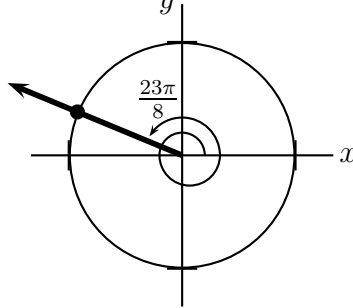

$$p = \left(-\frac{1}{2}\sqrt{2 + \sqrt{2}}, \frac{1}{2}\sqrt{2 - \sqrt{2}}\right)$$

4. (a) $\frac{\pi}{2}$, (b) $\frac{\pi}{3}$, (c) $\frac{\pi}{4}$, (d) $\frac{\pi}{3}$, (e) $\frac{\pi}{8}$, (f) $\frac{3\pi}{8}$, (g) $\frac{5\pi}{8}$, (h) $\frac{\pi}{8}$

5. (a) $\cos(\theta + \pi) = \frac{5}{13}$, $\sin(\theta + \pi) = \frac{12}{13}$, (b) $\cos(-\theta) = \frac{-5}{13}$, $\sin(-\theta) = \frac{12}{13}$,
(c) $\cos(\pi - \theta) = \frac{5}{13}$, $\sin(\pi - \theta) = \frac{-12}{13}$

6. Refer to problem 2

(a)

$$\sec\left(\frac{3\pi}{2}\right) = \frac{1}{\cos\left(\frac{3\pi}{2}\right)} = \text{undefined} \quad \tan\left(\frac{3\pi}{2}\right) = \frac{\sin\left(\frac{3\pi}{2}\right)}{\cos\left(\frac{3\pi}{2}\right)} = \text{undefined}$$

(b)

$$\sec\left(\frac{4\pi}{3}\right) = \frac{1}{\cos\left(\frac{4\pi}{3}\right)} = -2 \quad \tan\left(\frac{4\pi}{3}\right) = \frac{\sin\left(\frac{4\pi}{3}\right)}{\cos\left(\frac{4\pi}{3}\right)} = \sqrt{3}$$

(c)

$$\sec\left(\frac{5\pi}{4}\right) = \frac{1}{\cos\left(\frac{5\pi}{4}\right)} = -\sqrt{2} \quad \tan\left(\frac{5\pi}{4}\right) = \frac{\sin\left(\frac{5\pi}{4}\right)}{\cos\left(\frac{5\pi}{4}\right)} = 1$$

(d)

$$\sec\left(\frac{13\pi}{3}\right) = \frac{1}{\cos\left(\frac{13\pi}{3}\right)} = 2 \quad \tan\left(\frac{13\pi}{3}\right) = \frac{\sin\left(\frac{13\pi}{3}\right)}{\cos\left(\frac{13\pi}{3}\right)} = \sqrt{3}$$

7. Refer to problem 3

(a)

$$\csc\left(-\frac{\pi}{8}\right) = \frac{1}{\sin\left(-\frac{\pi}{8}\right)} = -\frac{2}{\sqrt{2-\sqrt{2}}} \quad \cot\left(-\frac{\pi}{8}\right) = \frac{\cos\left(-\frac{\pi}{8}\right)}{\sin\left(-\frac{\pi}{8}\right)} = -\frac{\sqrt{2+\sqrt{2}}}{\sqrt{2-\sqrt{2}}}$$

(b)

$$\csc\left(\frac{3\pi}{8}\right) = \frac{1}{\sin\left(\frac{3\pi}{8}\right)} = \frac{2}{\sqrt{2+\sqrt{2}}} \quad \cot\left(\frac{3\pi}{8}\right) = \frac{\cos\left(\frac{3\pi}{8}\right)}{\sin\left(\frac{3\pi}{8}\right)} = \frac{\sqrt{2-\sqrt{2}}}{\sqrt{2+\sqrt{2}}}$$

(c)

$$\csc\left(\frac{13\pi}{8}\right) = \frac{1}{\sin\left(\frac{13\pi}{8}\right)} = -\frac{2}{\sqrt{2+\sqrt{2}}} \quad \cot\left(\frac{13\pi}{8}\right) = \frac{\cos\left(\frac{13\pi}{8}\right)}{\sin\left(\frac{13\pi}{8}\right)} = \frac{\sqrt{2-\sqrt{2}}}{\sqrt{2+\sqrt{2}}}$$

(d)

$$\csc\left(\frac{23\pi}{8}\right) = \frac{1}{\sin\left(\frac{23\pi}{8}\right)} = \frac{2}{\sqrt{2-\sqrt{2}}} \quad \cot\left(\frac{23\pi}{8}\right) = \frac{\cos\left(\frac{23\pi}{8}\right)}{\sin\left(\frac{23\pi}{8}\right)} = -\frac{\sqrt{2+\sqrt{2}}}{\sqrt{2-\sqrt{2}}}$$

8. $\sin(\theta) = \frac{-\sqrt{21}}{5}$, $\tan(\theta) = \frac{-\sqrt{21}}{2}$, $\cot(\theta) = \frac{-2}{\sqrt{21}}$, $\sec(\theta) = \frac{5}{2}$, $\csc(\theta) = \frac{-5}{\sqrt{21}}$

9. $\csc(\theta) = \frac{-\sqrt{13}}{2}$, $\sin(\theta) = \frac{-2}{\sqrt{13}}$, $\cos(\theta) = \frac{-3}{\sqrt{13}}$, $\tan(\theta) = \frac{2}{3}$, $\sec(\theta) = \frac{-\sqrt{13}}{3}$

2.3 Graphs of Sine and Cosine

Since we can evaluate sine and cosine, we can now sketch their graphs. First we evaluate sine and cosine for all the angles between 0° and 360° that are multiples of 45° .

θ	$\sin \theta$	$\cos \theta$
0	0	1
$\frac{\pi}{4}$	$1/\sqrt{2}$	$1/\sqrt{2}$
$\frac{\pi}{2}$	1	0
$\frac{3\pi}{4}$	$1/\sqrt{2}$	$-1/\sqrt{2}$
π	0	-1
$\frac{5\pi}{4}$	$-1/\sqrt{2}$	$-1/\sqrt{2}$
$\frac{3\pi}{2}$	-1	0
$\frac{7\pi}{4}$	$-1/\sqrt{2}$	$1/\sqrt{2}$
2π	0	1

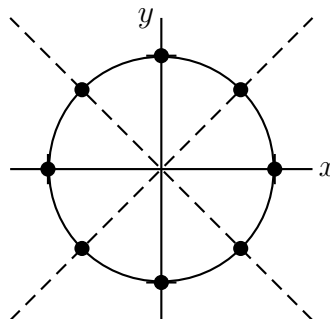

Now we sketch the graph of sine.

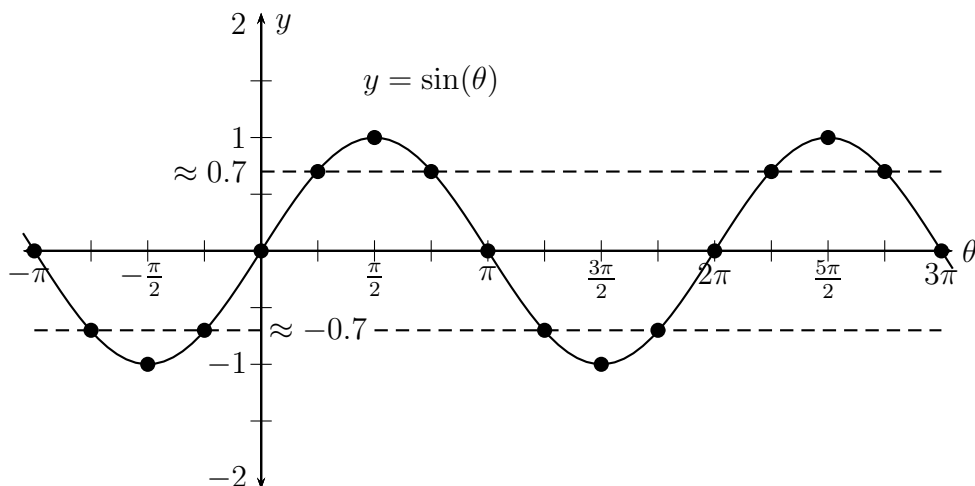

Sketch the graph of cosine below.

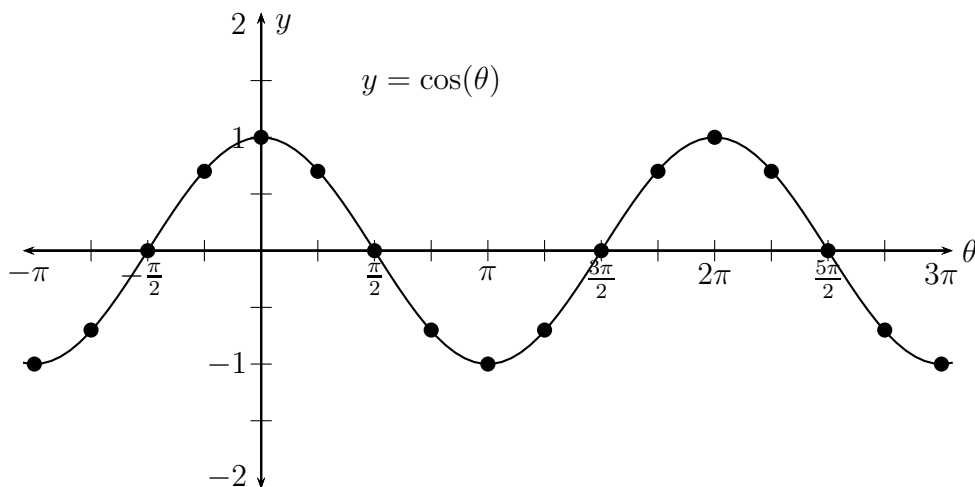

Definition: A function is **even** if it satisfies the equation: $f(-x) = f(x)$.
 This is equivalent to saying **the graph of f is symmetric about the y -axis**.

Definition: A function is **odd** if it satisfies the equation: $f(-x) = -f(x)$.
 This is equivalent to saying **the graph of f is symmetric about the origin**.

Looking at the graphs it's easy to see that **sine is odd** while **cosine is even**.

2.3.1 Amplitude and Period

Before continuing with our discussion of the graphs of functions involving sine and cosine, we need first discuss the concept of periodic functions in general.

Definition: A function is **periodic** if there is a number p so that:
 $f(x + p) = f(x)$ for every $x \in \text{Domain}(f)$.
 The smallest positive such number p is called the **period** of f .

Informally, this means f **repeats** every p units.

Example 2.26: The following graph is periodic. What is the period?

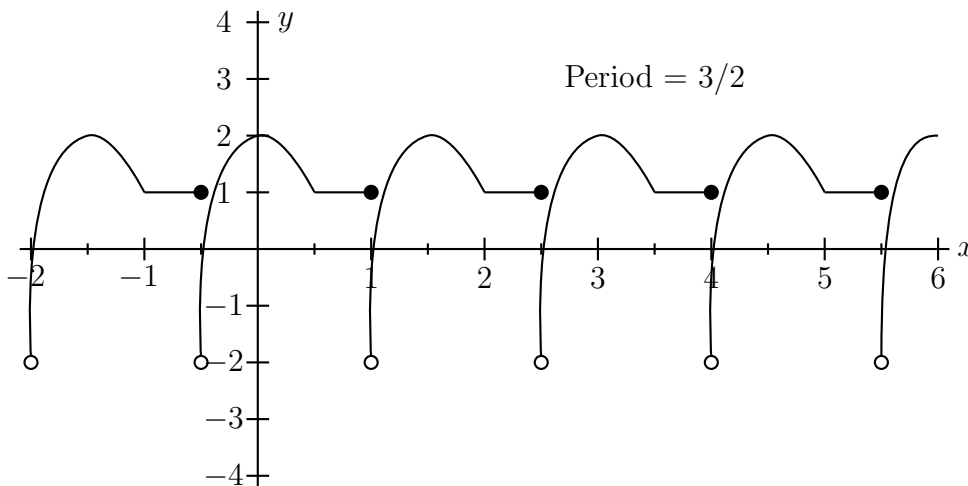

Example 2.27: The following graph is periodic. What is the period?

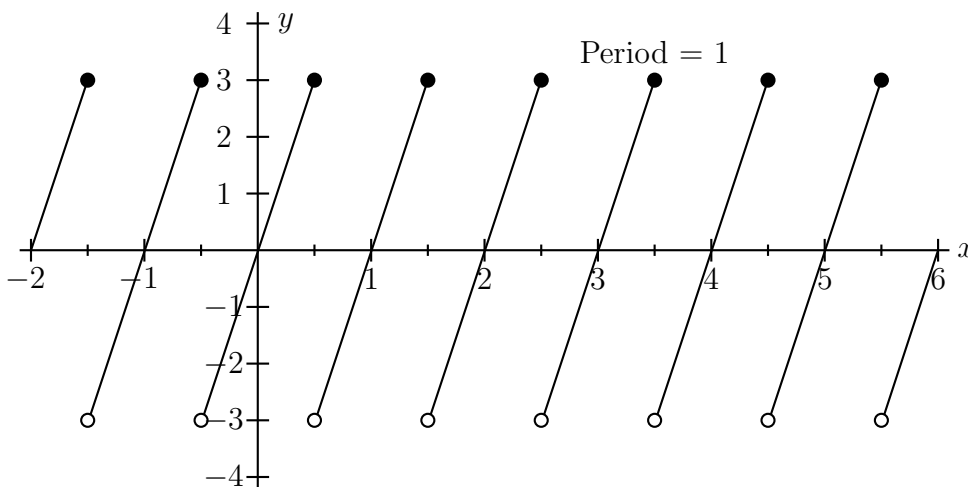

Looking at the graphs of sine and cosine, it is clear that each have a period of 2π .

$$\sin(\theta + 2\pi) = \sin(\theta) \quad \text{and} \quad \cos(\theta + 2\pi) = \cos(\theta)$$

since $\theta + 2\pi$ and θ are **co-terminal** angles, have the same terminal side, and thus have the same sine and cosine.

What is the period of $\sin(2\theta)$?

θ	$\sin 2\theta$
0	$\sin(2 \cdot 0) = \sin(0) = 0$
$\frac{\pi}{4}$	$\sin\left(2 \cdot \frac{\pi}{4}\right) = \sin \frac{\pi}{2} = 1$
$\frac{\pi}{2}$	$\sin\left(2 \cdot \frac{\pi}{2}\right) = \sin \pi = 0$
$\frac{3\pi}{4}$	$\sin\left(2 \cdot \frac{3\pi}{4}\right) = \sin \frac{3\pi}{2} = -1$
π	$\sin(2 \cdot \pi) = \sin 2\pi = 0$
$\frac{5\pi}{4}$	$\sin\left(2 \cdot \frac{5\pi}{4}\right) = \sin \frac{5\pi}{2} = 1$
$\frac{3\pi}{2}$	$\sin\left(2 \cdot \frac{3\pi}{2}\right) = \sin 3\pi = 0$
$\frac{7\pi}{4}$	$\sin\left(2 \cdot \frac{7\pi}{4}\right) = \sin \frac{7\pi}{2} = -1$
2π	$\sin(2 \cdot 2\pi) = \sin(4\pi) = 0$

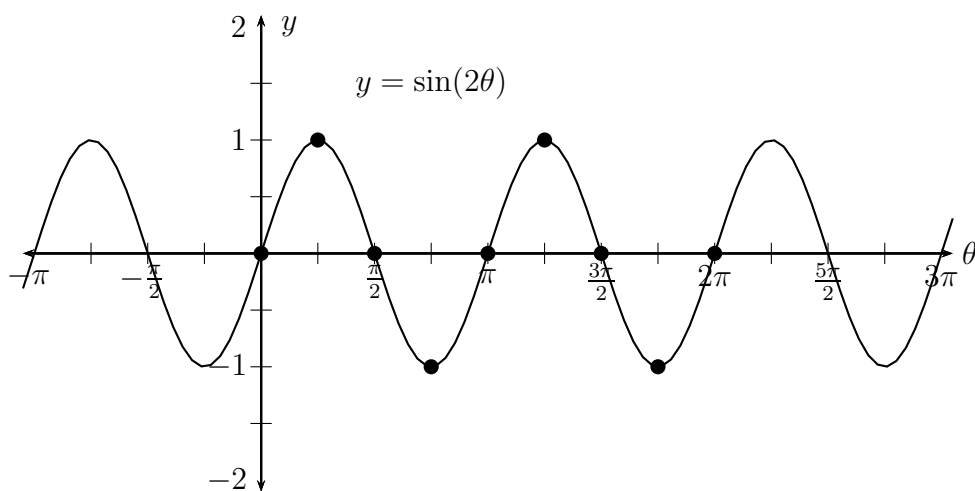

It's easy to see the period of $\sin 2\theta$ is π . This is sensible since multiplying by 2 on the **inside** should **squeeze the graph horizontally by a factor of 2**. This divides the period by 2.

If you multiply on the inside by any $b > 0$, then you will divide the period by b . Hence, the period of $\sin(b\theta)$ or $\cos(b\theta)$ is $\frac{2\pi}{b}$

Example 2.28: What is the period of the function: $\cos(\pi\theta)$?

Solution: period = $\frac{2\pi}{\pi} = 2$.

Example 2.29: What is the period of the function: $\sin\left(\frac{\theta}{2}\right)$?

$$\text{period} = \frac{2\pi}{\frac{1}{2}} = 4\pi.$$

What about the period of $2\sin\theta$? How does multiplying by 2 on the **outside** effect the period?

θ	$2\sin\theta$
0	$2\sin(0) = 2 \cdot 0 = 0$
$\frac{\pi}{4}$	$2\sin\left(\frac{\pi}{4}\right) = 2 \cdot \frac{1}{\sqrt{2}} = \sqrt{2}$
$\frac{\pi}{2}$	$2\sin\left(\frac{\pi}{2}\right) = 2 \cdot 1 = 2$
$\frac{3\pi}{4}$	$2\sin\left(\frac{3\pi}{4}\right) = 2 \cdot \frac{1}{\sqrt{2}} = \sqrt{2}$
π	$2\sin(\pi) = 2 \cdot 0 = 0$
$\frac{5\pi}{4}$	$2\sin\left(\frac{5\pi}{4}\right) = 2 \cdot \left(-\frac{1}{\sqrt{2}}\right) = -\sqrt{2}$
$\frac{3\pi}{2}$	$2\sin\left(\frac{3\pi}{2}\right) = 2 \cdot -1 = -2$
$\frac{7\pi}{4}$	$2\sin\left(\frac{7\pi}{4}\right) = 2 \cdot \left(-\frac{1}{\sqrt{2}}\right) = -\sqrt{2}$
2π	$2\sin(2\pi) = 2 \cdot 0 = 0$

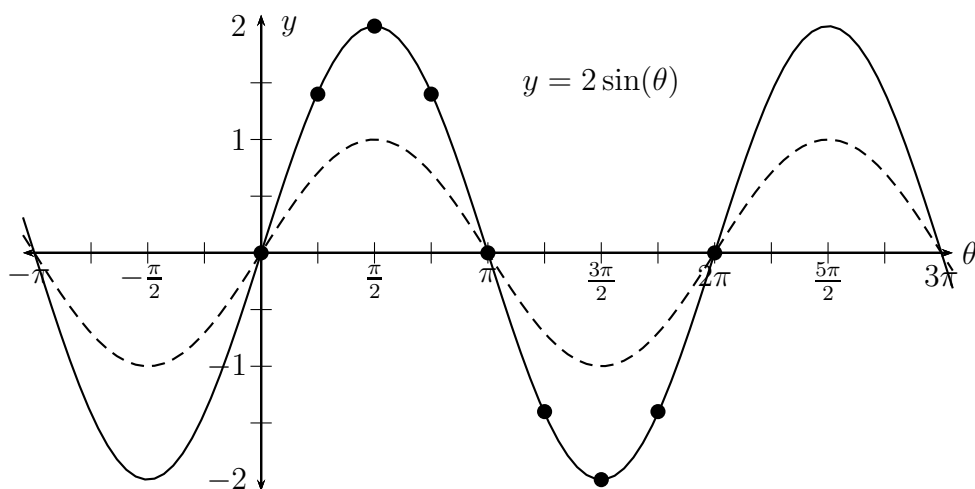

The period is still 2π . So the answer is multiplying by 2 on the outside **does not change the period**. This is sensible since the period is a characteristic of the **domain**, and multiplying on the outside effects only the **range**.

Definition: The **amplitude** of a sine or cosine function is: $\frac{1}{2}(\text{maximum} - \text{minimum})$.

Example 2.30: What is the amplitude of $\sin(2\theta)$?

$$\text{amplitude} = \frac{1 - (-1)}{2} = 1$$

Example 2.31: What is the amplitude of $2\sin(\theta)$?

$$\text{amplitude} = \frac{2 - (-2)}{2} = 2$$

It's pretty easy to see that the amplitude of $a\sin(b\theta)$ or $a\cos(b\theta)$ is $|a|$.

Example 2.32: What is the period and amplitude of the sinusoidal function whose graph is given below?

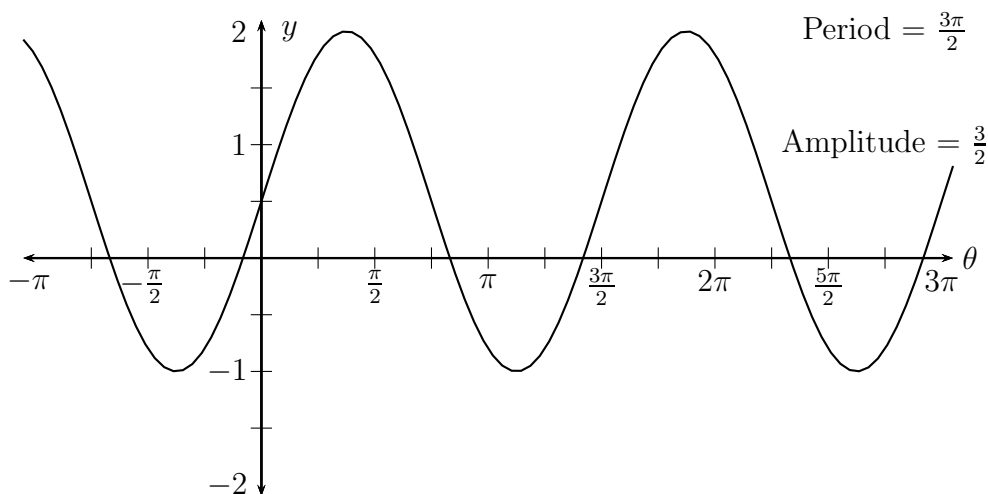

Recipe for graphing $a\sin(b\theta)$ or $a\cos(b\theta)$:

1. Find the period and amplitude.
2. Measure or label the x -axis for a convenient period, and the y -axis for a convenient amplitude.
3. Divide the period into quarters. Then mark the zeros, maxima, and minima for one period of the function.
(sine goes: zero-max-zero-min-zero, while cosine goes: max-zero-min-zero-max)
4. Extend the zeros, maxima, and minima, and then draw a nice smooth curve.

Example 2.33: Sketch the graph of $3 \cos(\pi x)$.

1. period = $\frac{2\pi}{\pi} = 2$. The amplitude is 3.
2. Label axes conveniently.

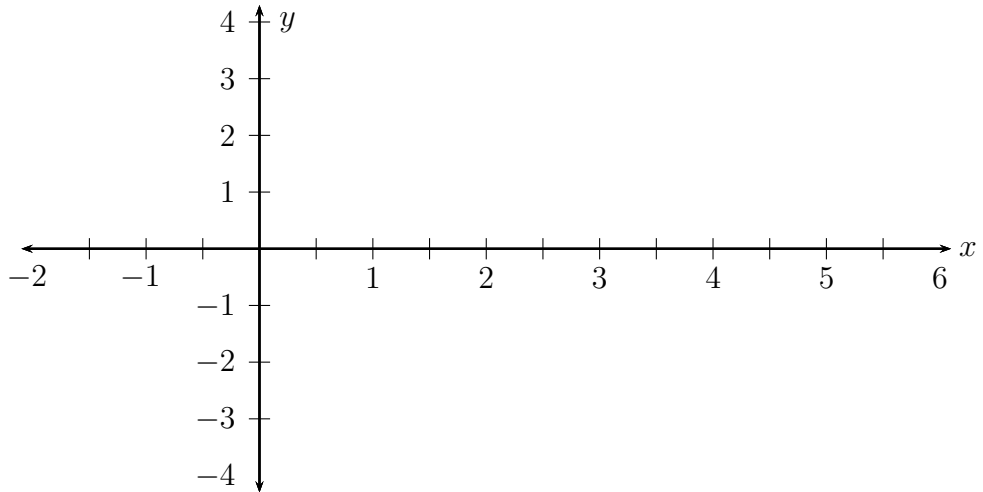

3. Mark zeros, maxima, and minima for one period (0 to 2).

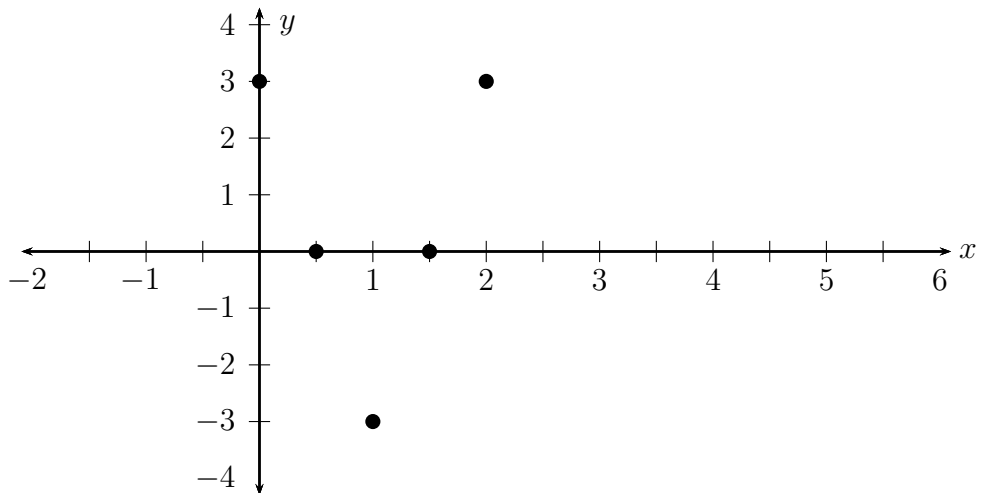

4. Fill in remaining zeros, maxima, and minima. Draw a smooth curve.

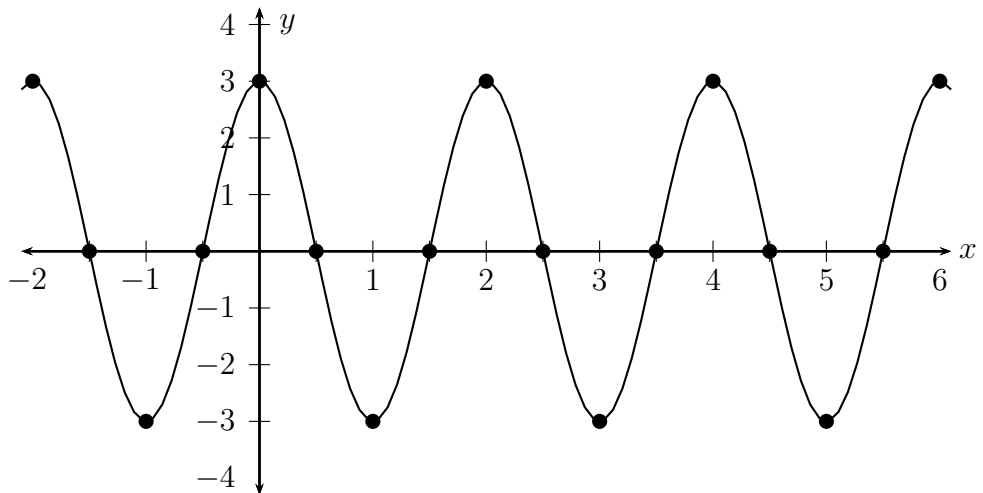

Example 2.34: Sketch the graph of $10 \sin\left(\frac{\theta}{2}\right)$.

period = 4π

amplitude = 10

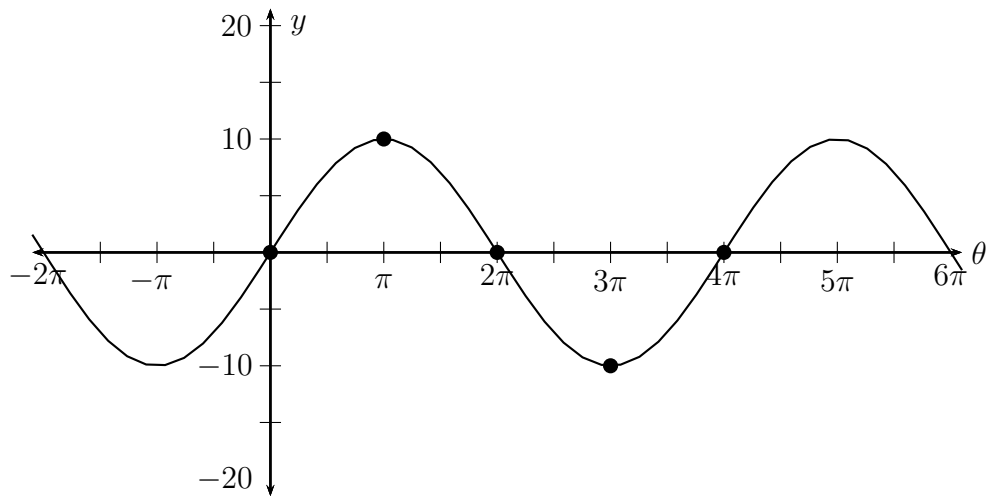

2.3.2 Phase Shift and Vertical Shift

We've seen that multiplying on the outside produces a vertical stretch (changing the amplitude) while multiplying on the inside produces a horizontal squeeze (changing the period).

What happens if we **add** rather than multiply? This should produce a horizontal or vertical **shift**. Adding on the **inside** will shift the graph **horizontally**. This is called a **phase shift**. Adding on the **outside** will shift the graph **vertically**. This is a **vertical shift**.

Example 2.35: Sketch the graph of $\sin(\theta + \frac{\pi}{4})$.

θ	$\sin(\theta + \frac{\pi}{4})$
0	$\sin(0 + \frac{\pi}{4}) = \sin \frac{\pi}{4} = \frac{1}{\sqrt{2}}$
$\frac{\pi}{4}$	$\sin(\frac{\pi}{4} + \frac{\pi}{4}) = \sin \frac{\pi}{2} = 1$
$\frac{\pi}{2}$	$\sin(\frac{\pi}{2} + \frac{\pi}{4}) = \sin \frac{3\pi}{4} = \frac{1}{\sqrt{2}}$
$\frac{3\pi}{4}$	$\sin(\frac{3\pi}{4} + \frac{\pi}{4}) = \sin \pi = 0$
π	$\sin(\pi + \frac{\pi}{4}) = \sin \frac{5\pi}{4} = -\frac{1}{\sqrt{2}}$
$\frac{5\pi}{4}$	$\sin(\frac{5\pi}{4} + \frac{\pi}{4}) = \sin \frac{3\pi}{2} = -1$
$\frac{3\pi}{2}$	$\sin(\frac{3\pi}{2} + \frac{\pi}{4}) = \sin \frac{7\pi}{4} = -\frac{1}{\sqrt{2}}$
$\frac{7\pi}{4}$	$\sin(\frac{7\pi}{4} + \frac{\pi}{4}) = \sin 2\pi = 0$
2π	$\sin(2\pi + \frac{\pi}{4}) = \sin \frac{9\pi}{4} = \frac{1}{\sqrt{2}}$

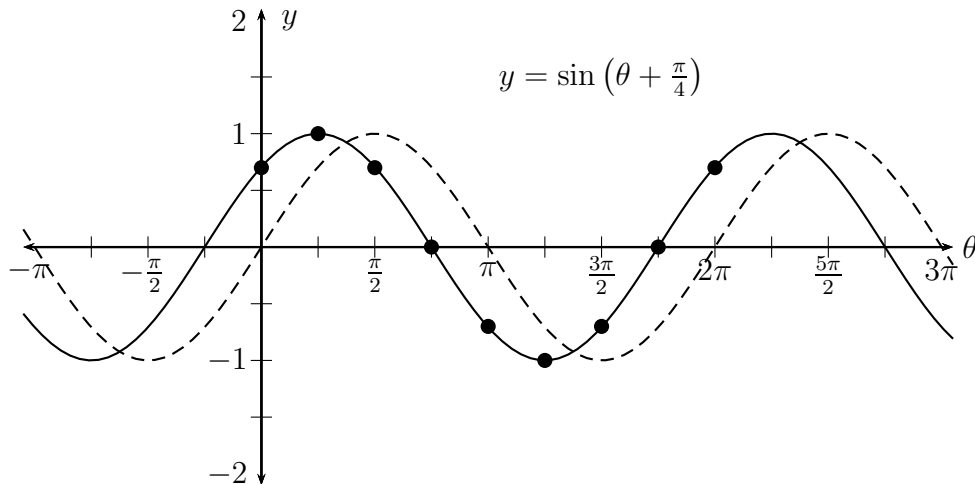

We added $\frac{\pi}{4}$ on the inside. This caused the graph of $\sin \theta$ to shift left $\frac{\pi}{4}$ units. We say $\sin(\theta + \frac{\pi}{4})$ has a **phase shift of $-\frac{\pi}{4}$** . (Negative because the graph moved in the negative direction, a.k.a left.)

Example 2.36:

Sketch the graph of $\sin(\theta) + 1$.

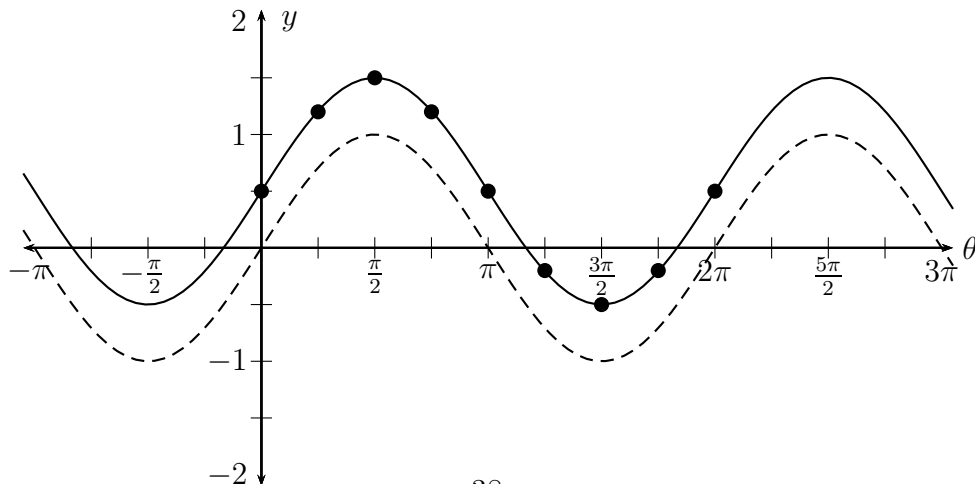

Example 2.37: What is the phase shift of $\sin\left(2\theta + \frac{\pi}{4}\right)$?

Solution: This is more complicated than it seems. First you shift left $\frac{\pi}{4}$, then you squeeze by a factor of 2. When you're done the phase shift is half what it started as. The phase shift is $-\frac{\pi}{8}$.

Another way to see this is to factor the 2 out of the inside of the sine.

$$\sin\left(2\theta + \frac{\pi}{4}\right) = \sin\left(2\left(\theta + \frac{\pi}{8}\right)\right)$$

Hence the function $\sin(2\theta)$ is shifted left $\frac{\pi}{8}$.

In general then, the phase shift of $a \sin(b\theta + c)$ or $a \cos(b\theta + c)$ is $-\frac{c}{b}$

Notice, though, that shifting left or right (or up or down) does not change the period or the amplitude. So, the period of $a \sin(b\theta + c) + d$ or $a \cos(b\theta + c) + d$ is $\frac{2\pi}{b}$, and the amplitude is $|a|$ just as before.

Recipe for graphing $a \sin(b\theta + c) + d$ or $a \cos(b\theta + c) + d$:

1. Find the period, amplitude, phase shift, and vertical shift.
2. Measure or label the x -axis for a convenient period, and the y -axis for a convenient amplitude.
3. Divide the period into quarters. Then lightly mark the zeros, maxima, and minima for one period of the unshifted function, $a \sin(b\theta)$ or $a \cos(b\theta)$. Extend the zeros, maxima and minima.
4. Shift these points according to the phase or vertical shift calculated. Then draw a nice smooth curve connecting the points.

Example 2.38: Sketch the graph of $y = \sin\left(2\theta + \frac{\pi}{4}\right)$

Solution: The amplitude is 1, period π , phase shift $-\pi/8$, with 0 vertical shift.

Label axes conveniently.

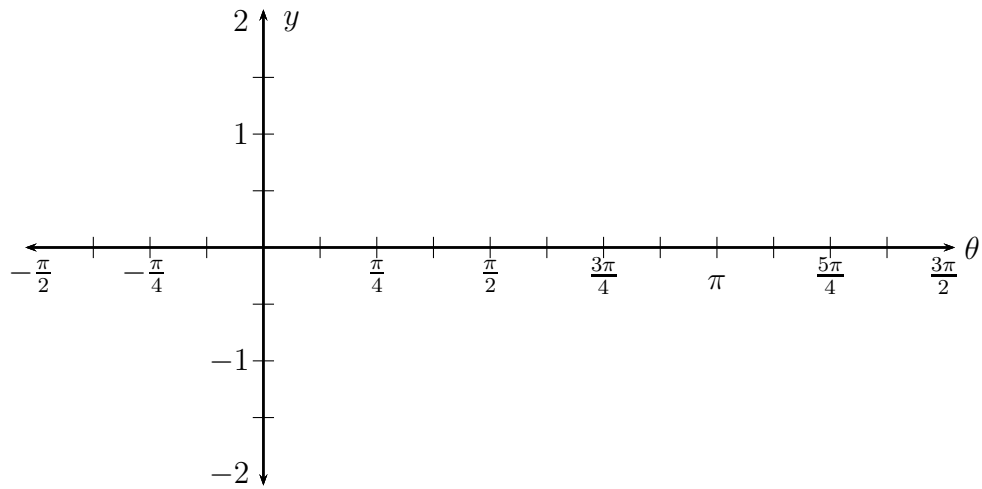

Lightly mark zeros, maxima, and minima for one period (0 to π) of $y = \sin(2\theta)$. Extend.

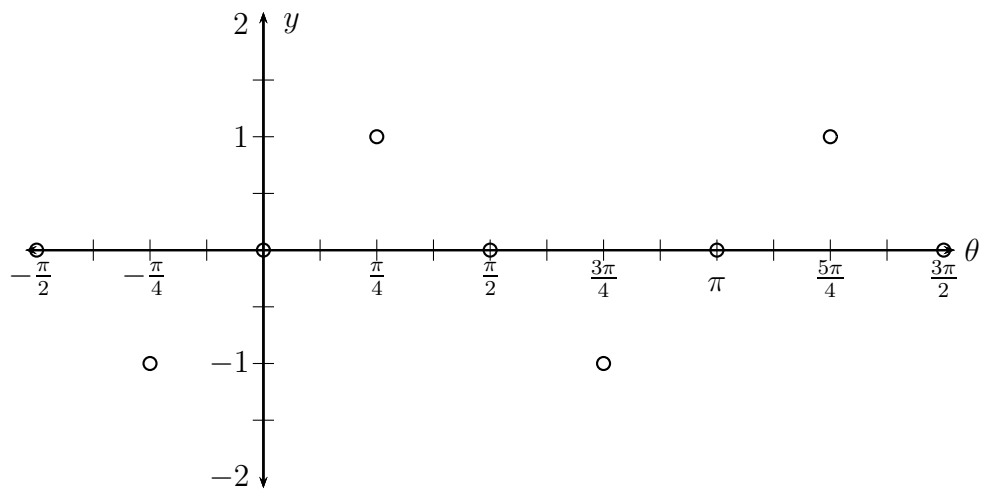

Shift each mark left $\pi/8$. Draw a smooth curve.

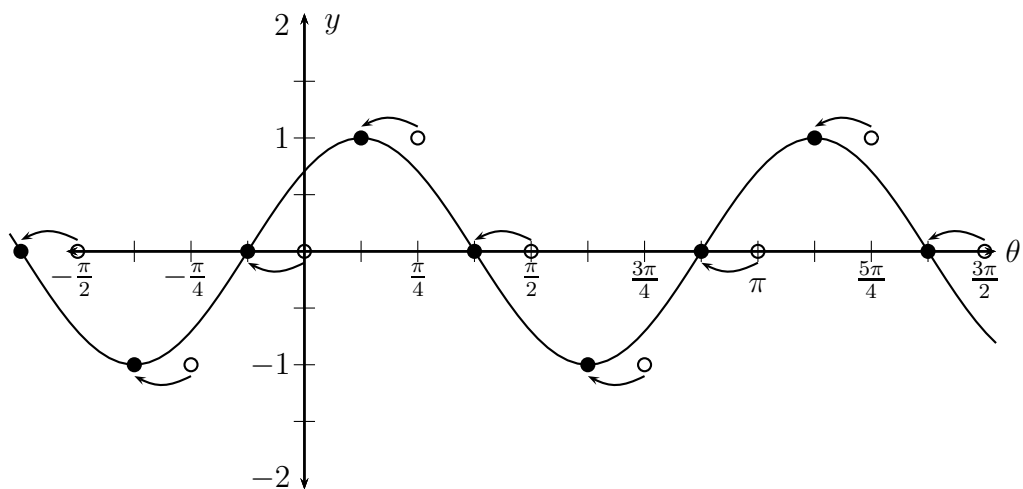

Example 2.39: Sketch the graph of $y = 3 \cos(\pi\theta + \pi)$

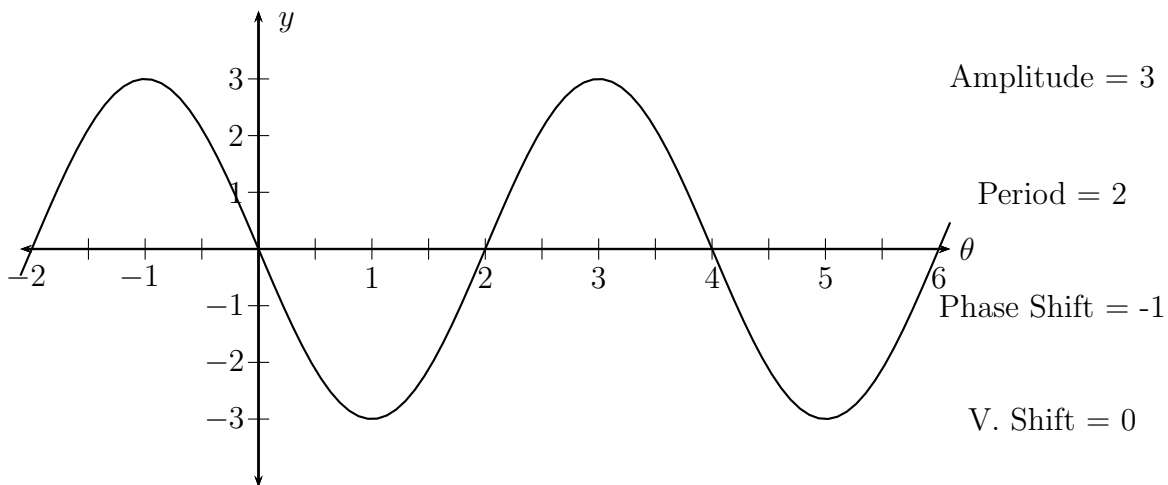

Example 2.40: Sketch the graph of $y = 2 \sin\left(2\pi\theta - \frac{\pi}{3}\right) - 1$

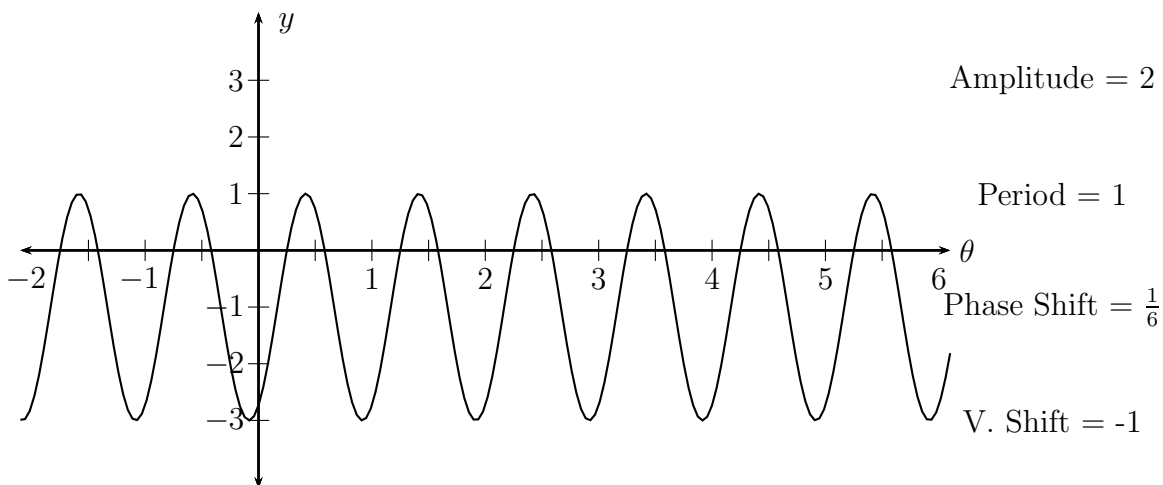

Now let's try going the other way.

Example 2.41: Below is the graph of $y = a \sin(b\theta + c) + d$. Find the constants a, b, c, d .

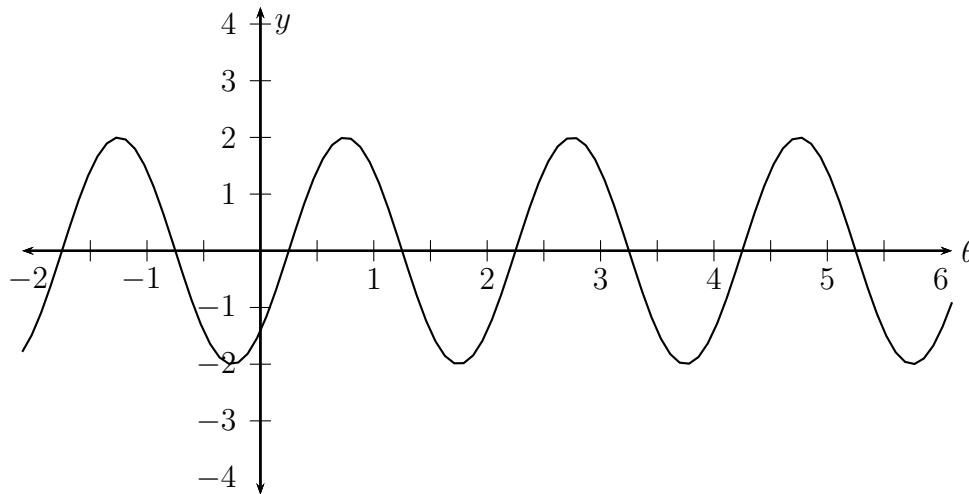

Solution: The amplitude is 2, so let $a = 2$. The period is also 2, so:

$$\frac{2\pi}{b} = 2 \quad \Rightarrow \quad 2\pi = 2b \quad \Rightarrow \quad b = \pi$$

The phase shift is $+\frac{1}{4}$ so:

$$-\frac{c}{b} = \frac{1}{4} \quad \Rightarrow \quad -\frac{c}{\pi} = \frac{1}{4} \quad \Rightarrow \quad c = -\frac{\pi}{4}$$

There is no vertical shift, so the answer is: $y = 2 \sin\left(\pi\theta - \frac{\pi}{4}\right)$

Notice this is **not** the only possible answer. We might chose a phase shift of $-\frac{7}{4}$ or $\frac{9}{4}$ (these are both also correct). They would give us a different c 's. Likewise we could have chosen $a = -2$. This would produce a phase shift of $-\frac{3}{4}$. ($2 \sin(\pi\theta)$ moved left $\frac{3}{4}$ and then flipped over the x -axis!) Usually it's easiest to chose $a > 0$ and find c for the smallest possible phase shift.

Example 2.42: Below is the graph of $y = a \sin(b\theta + c) + d$. Find the constants a, b, c, d .

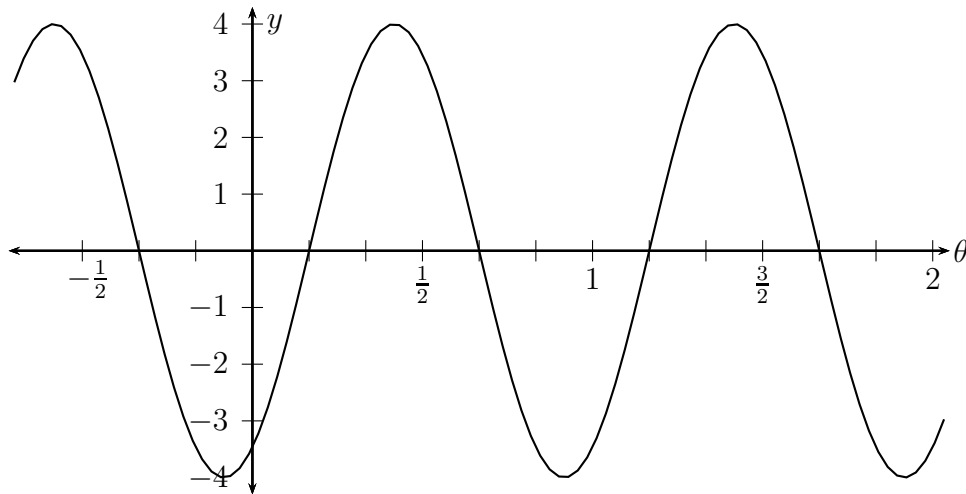

The amplitude is 4, so let $a = 4$. The period is 1, so:

$$\frac{2\pi}{b} = 1 \Rightarrow b = 2\pi$$

The phase shift is $+\frac{1}{6}$ so:

$$-\frac{c}{b} = \frac{1}{6} \Rightarrow -\frac{c}{2\pi} = \frac{1}{6} \Rightarrow c = -\frac{\pi}{3}$$

There is no vertical shift, so the answer is: $y = 4 \sin\left(2\pi\theta - \frac{\pi}{3}\right)$

Example 2.43: Solve example 2.42 if it were the graph of $y = a \cos(b\theta + c) + d$

The only difference is that the phase shift is now $\frac{5}{12}$ (half way between $\frac{1}{3}$ and $\frac{1}{2}$). So,

$$-\frac{c}{b} = \frac{5}{12} \Rightarrow -\frac{c}{2\pi} = \frac{5}{12} \Rightarrow c = -\frac{5\pi}{6}$$

$$y = 4 \cos\left(2\pi\theta - \frac{5\pi}{6}\right)$$

Example 2.44: Below is the graph of $y = a \sin(b\theta + c) + d$. Find the constants a, b, c, d .

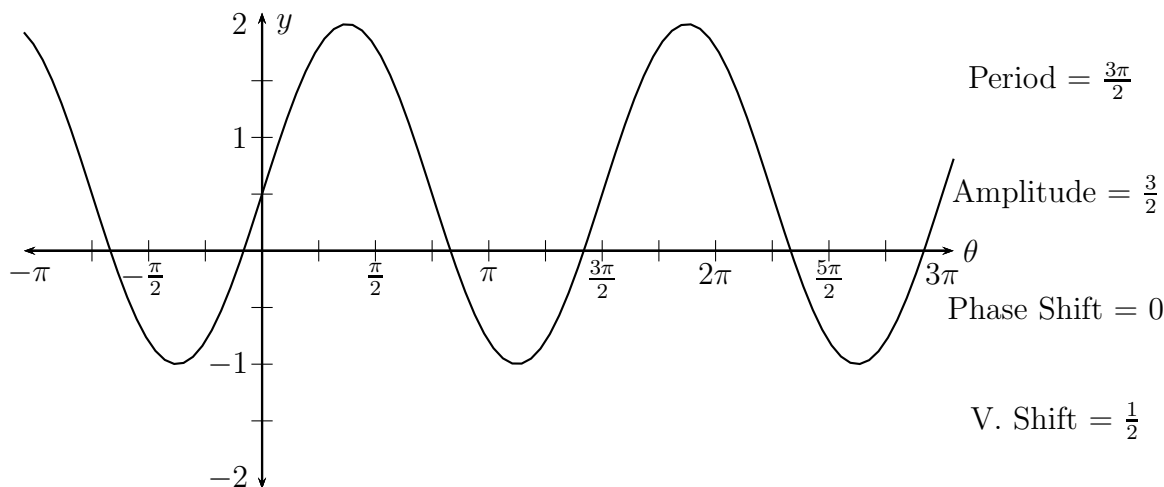

$$a = \frac{3}{2}, \quad \frac{2\pi}{b} = \frac{3\pi}{2} \Rightarrow b = \frac{4}{3}, \quad c = 0$$

$$\boxed{y = \frac{3}{2} \sin\left(\frac{4}{3}\theta\right) + \frac{1}{2}}$$

Homework 2.3

Further practice: Page 439 (sec 5.3) #1-40,49,50

1. Give the amplitude and period of the functions below, then sketch their graphs.
 - (a) $y = \cos(4x)$
 - (b) $y = -2 \sin(2\pi x)$
 - (c) $y = 10 \cos\left(\frac{\pi}{3}\right)$
 - (d) $y = \sin(-2x)$
2. Give the amplitude, period, phase shift, and vertical shift of the functions below, then sketch their graphs.
 - (a) $y = 3 \cos\left(x + \frac{\pi}{4}\right)$
 - (b) $y = 2 \sin\left(\frac{2}{3}x - \frac{\pi}{6}\right)$
 - (c) $y = 1 + \cos(3x)$
 - (d) $y = -2 + \sin\left(\pi x - \frac{\pi}{3}\right)$

3. R Leonis is a variable star whose brightness is modelled by the function:

$$b(t) = 7.9 - 2.1 \cos\left(\frac{\pi}{156}t\right)$$

where t is days and b is stellar magnitude.

- Find the period of R Leonis.
 - Find the maximum and minimum stellar magnitude.
 - Graph one period of b versus t .
4. Blood pressure rises and falls with the beating of the heart. The maximum blood pressure is called the *systolic* pressure, and the minimum is called the *diastolic* pressure. Blood pressure is usually given as *systolic/diastolic*. (120/80 is considered normal.)

Say a patient's blood pressure is modelled by the function:

$$p(t) = 115 + 25 \sin(160\pi t)$$

where t is in minutes and p is in millimeters of mercury (mmHG).

- Find the period of p .
- Find the number of heartbeats this patient has per minute.
- Graph two periods of p versus t .

5. Find sine functions whose graphs are the same as those given below.

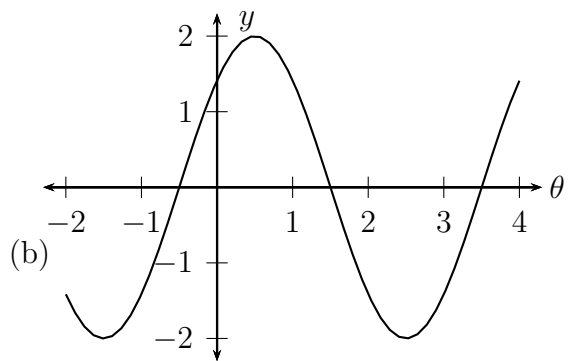
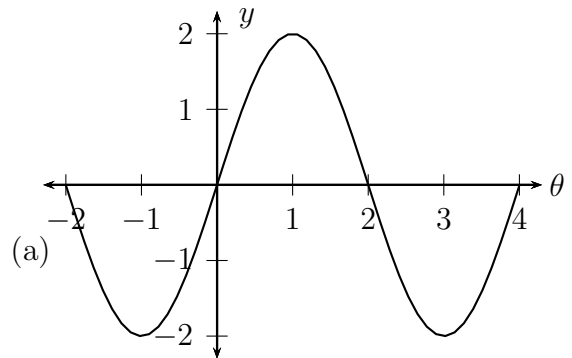

6. Find cosine functions whose graphs are the same as those given below.

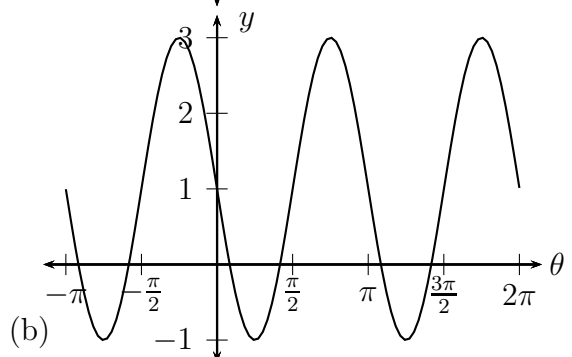
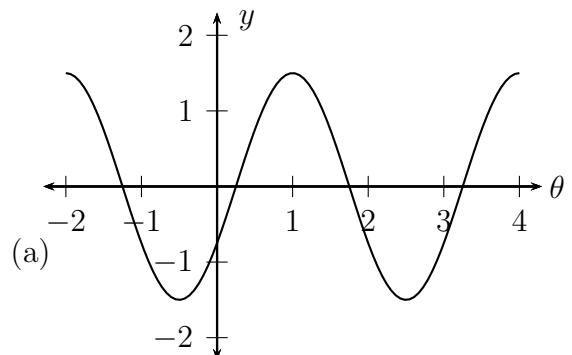

Solutions:

1. (a) amp = 1, period = $\frac{\pi}{2}$

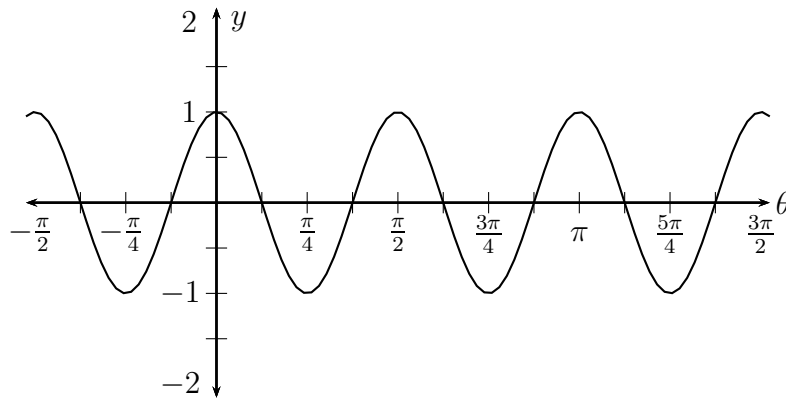

(b) amp = 2, period = 1

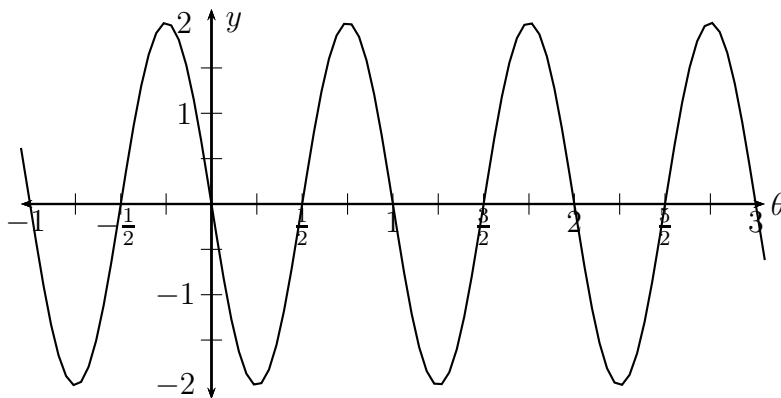

(c) $a = 10$, $p = 6\pi$, amp = 10, period = 6

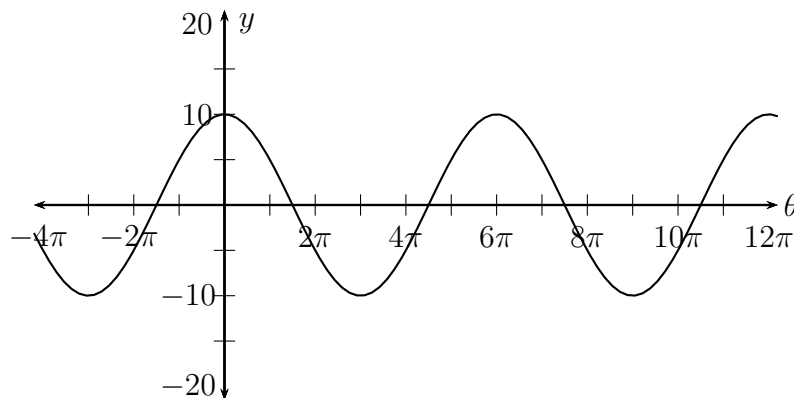

(d) amp = 1, period = π

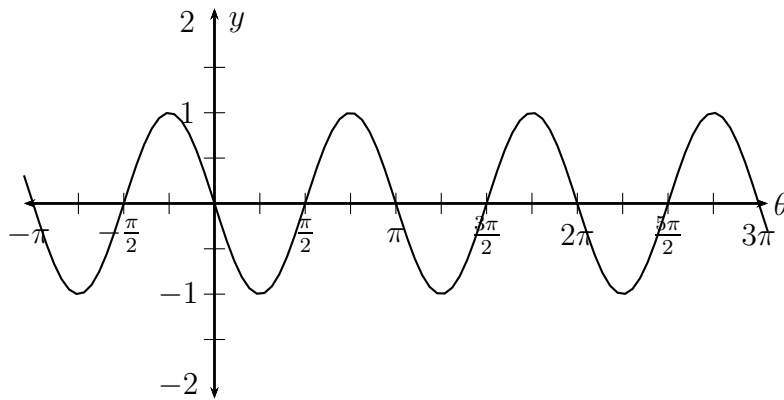

2. (a) amp = 3, period = 2π , phase shift = $-\frac{\pi}{4}$

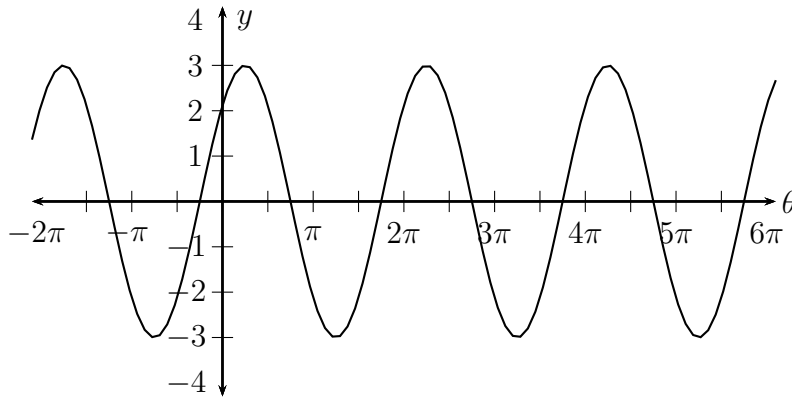

(b) amp = 2, period = 3π , phase shift = $\frac{\pi}{4}$

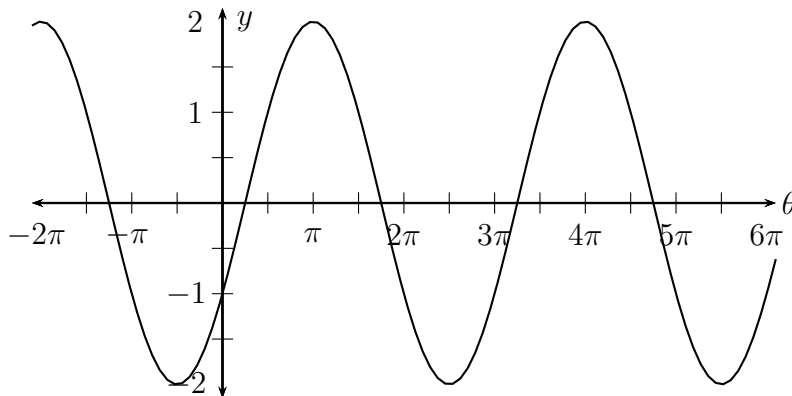

(c) amp = 1, period = $\frac{2\pi}{3}$, vertical shift = $\frac{1}{2}$

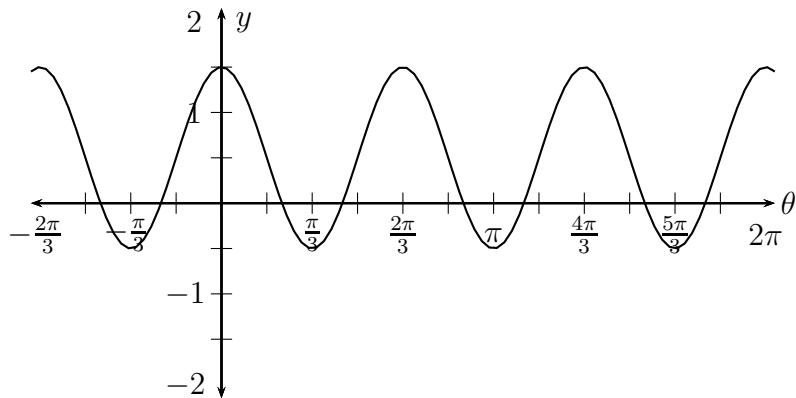

(d) amp = 1, period = 2, phase shift = $\frac{1}{3}$, vertical shift = -2

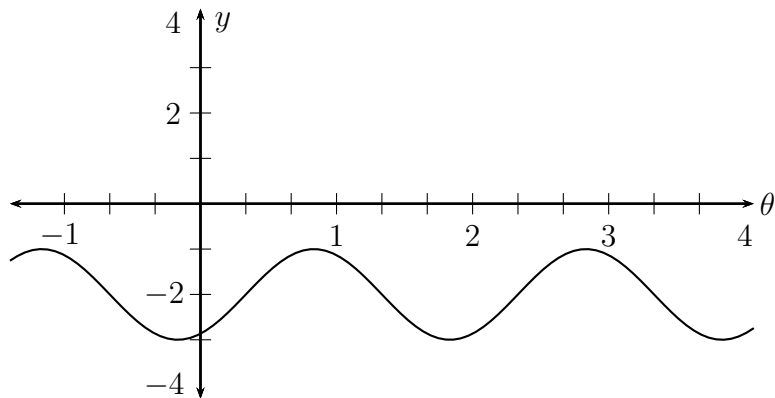

3. (a) 312 days, (b) Max is 10 and the minimum is 5.8 (c)

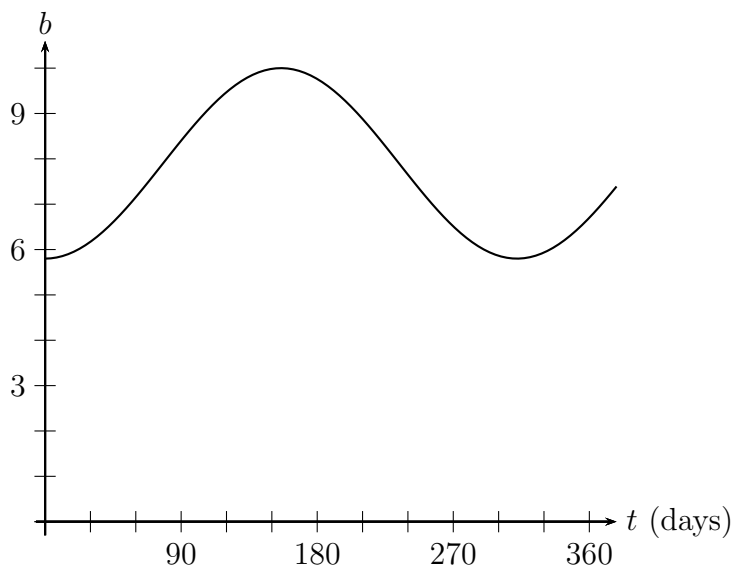

4. (a) $p = \frac{1}{80}$ minutes, (b) About 80 beats per minute (c)

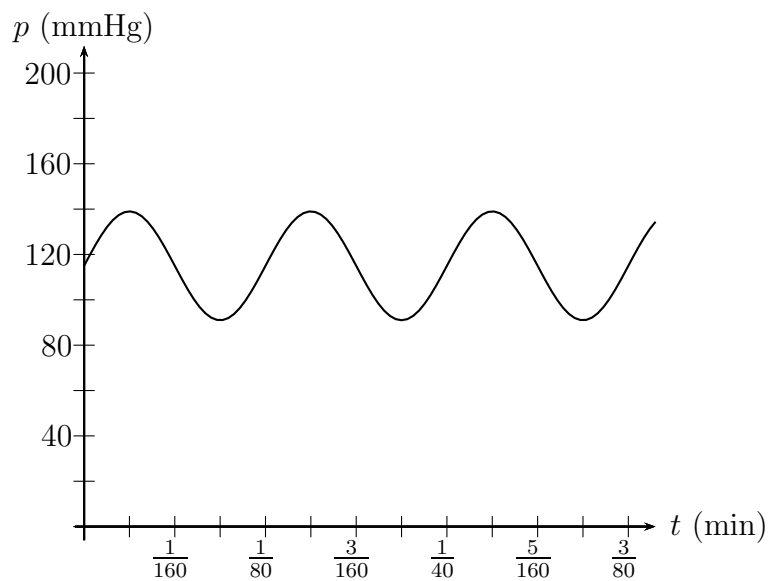

5. (a) $y = 2 \sin\left(\frac{\pi}{2}\theta\right)$
 (b) $y = 2 \sin\left(\frac{\pi}{2}\theta + \frac{\pi}{4}\right)$
6. (a) $y = \frac{3}{2} \cos\left(\frac{2\pi}{3}\theta - \frac{2\pi}{3}\right)$
 (b) $y = 2 \cos\left(2\theta + \frac{\pi}{2}\right) + 1$

2.4 Other Trig Graphs

Since the other trigonometric functions are fractions involving sine and cosine let's review the properties of functions defined as one function divided by another. In Math 111 we studied the case where a polynomial was divided by another polynomial. These were called **rational functions**.

Say f is a function defined as a “top” function, $T(x)$, divided by a “bottom” function $B(x)$.

$$f(x) = \frac{T(x)}{B(x)}$$

When $T(a) = 0$ and $B(a) \neq 0$ then $f(a) = 0$.

When $B(a) = 0$ and $T(a) \neq 0$ then $f(a)$ is not defined. In fact there is a **vertical asymptote** at $x = a$ in this case.

(When both T and B are zero anything can happen. This case is dealt with in Calculus.)

Example 2.45: Let $f(x) = \frac{x-1}{x+1}$.

Where is f zero? Where does f have a vertical asymptote?

Solution: f is zero when the top function is zero (and the bottom is not). Thus, $x - 1 = 0 \Rightarrow x = 1$. At $x = 1$ the bottom function is 2, so $f(1) = 0$.

f has a vertical asymptote when the bottom function is zero (and the top is not). Thus, $x + 1 = 0 \Rightarrow x = -1$. At $x = -1$ the top function is -2 , so f has a vertical asymptote at $x = -1$.

Here is the graph of f .

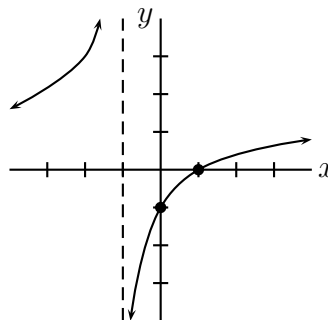

Now we consider the functions $\tan \theta = \frac{\sin \theta}{\cos \theta}$ and $\cot \theta = \frac{\cos \theta}{\sin \theta}$.

θ	$\tan \theta$	$\cot \theta$
0	$\frac{0}{1} = 0$	V.A.
$\frac{\pi}{4}$	$\frac{1/\sqrt{2}}{1/\sqrt{2}} = 1$	1
$\frac{\pi}{2}$	$\frac{1}{0} = \text{V.A.}$	0
$\frac{3\pi}{4}$	$\frac{1/\sqrt{2}}{-1/\sqrt{2}} = -1$	-1
π	$\frac{0}{-1} = 0$	V.A.
$\frac{5\pi}{4}$	$\frac{-1/\sqrt{2}}{-1/\sqrt{2}} = 1$	1
$\frac{3\pi}{2}$	$\frac{-1}{0} = \text{V.A.}$	0
$\frac{7\pi}{4}$	$\frac{-1/\sqrt{2}}{1/\sqrt{2}} = -1$	-1
2π	$\frac{0}{1} = 0$	V.A.

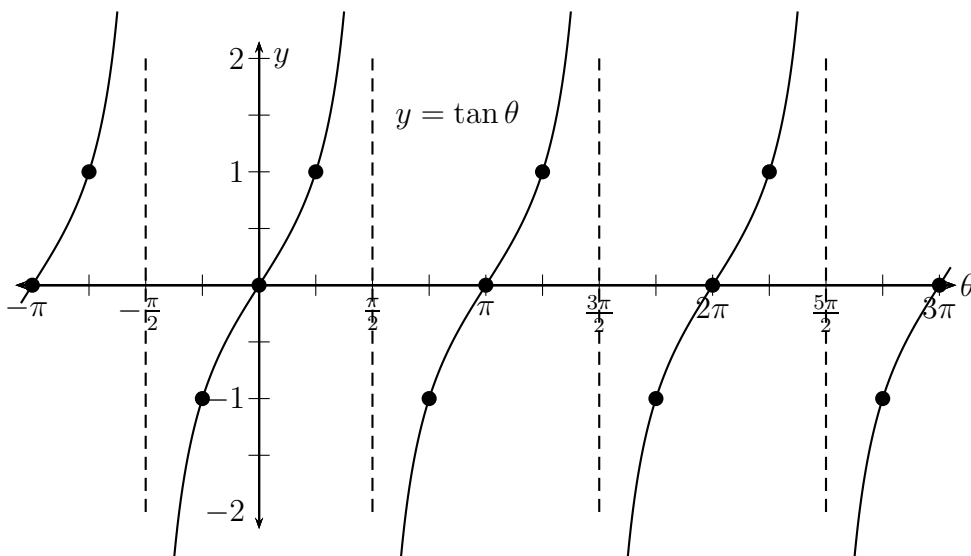

Sketch the graph of cotangent.

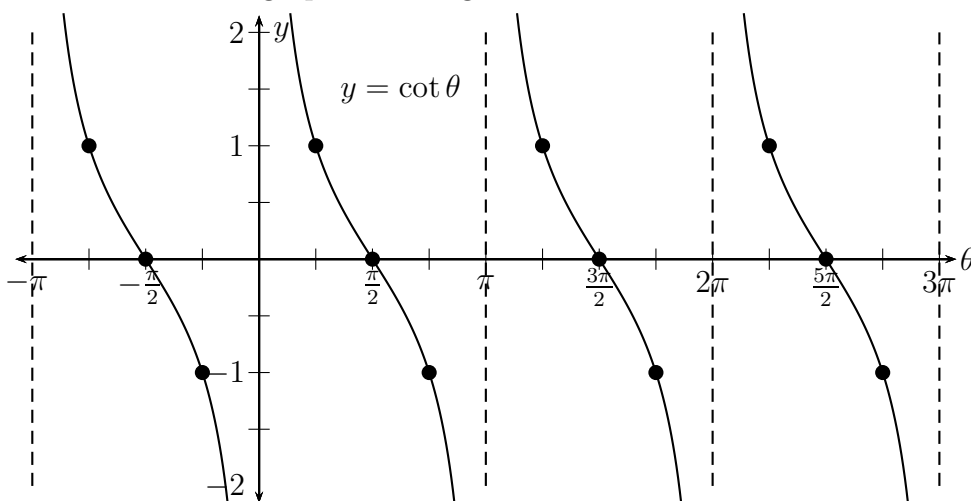

What is the period of tangent and cotangent?

By the same reasoning as we used for sine and cosine, for $a \tan(b\theta+c)+d$ or $a \cot(b\theta+c)+d$:

period = $\frac{\pi}{b}$ and phase shift = $-\frac{c}{b}$

Recipe for graphing tangent or cotangent:

1. Calculate period and phase shift.
2. Label the graph conveniently for your period and a .
3. Divide one period into quarters. Lightly mark zeros, vertical asymptotes, and quarter-points for $a \tan(b\theta)$ or $a \cot(b\theta)$.
(Tangent goes: 0, a , VA, $-a$, 0; Cotangent goes:)
4. Extend and shift marked points.
5. Draw a smooth curve.

Example 2.46: Sketch the graph of $y = \frac{1}{2} \tan\left(\frac{\theta}{3}\right)$.

1. period = $\frac{\pi}{1/3} = 3\pi$

There is no phase shift or vertical shift.

2. Label axes conveniently.

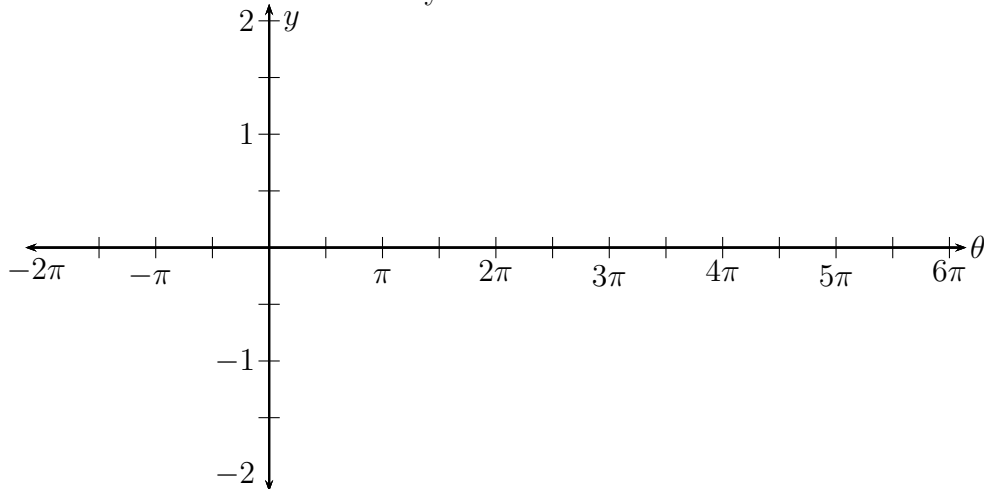

3. Mark zeros, vertical asymptotes and quarter-points for one period.
(0 to 3π)

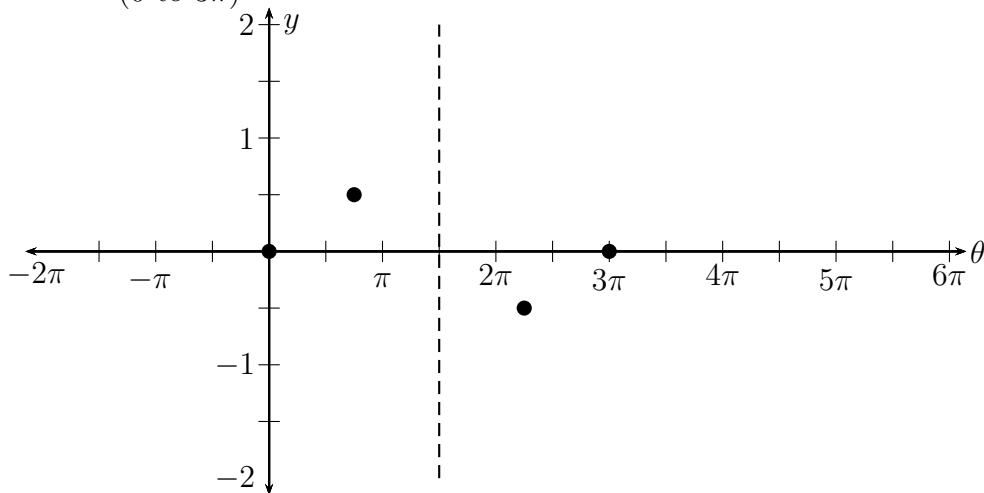

4. Extend.

5. Draw a smooth curve.

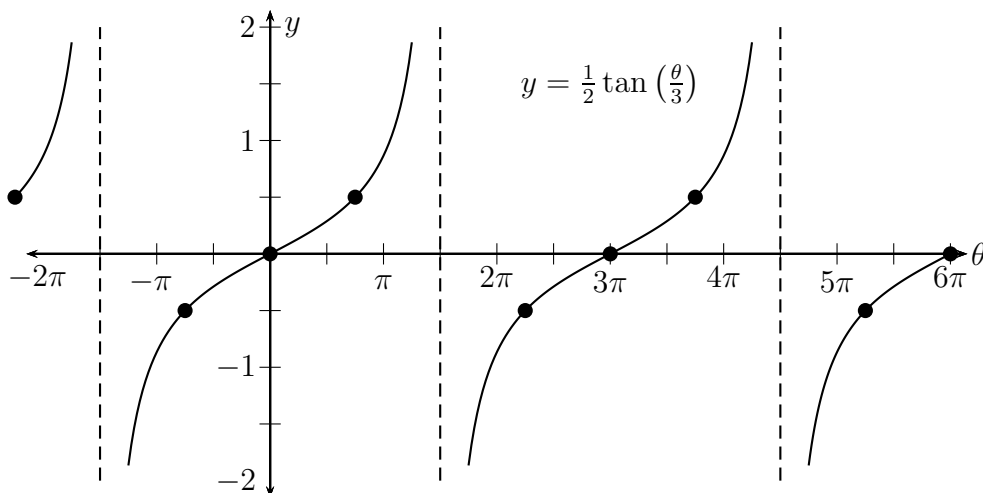

Example 2.47: Sketch $y = 2 \cot(\pi\theta)$.

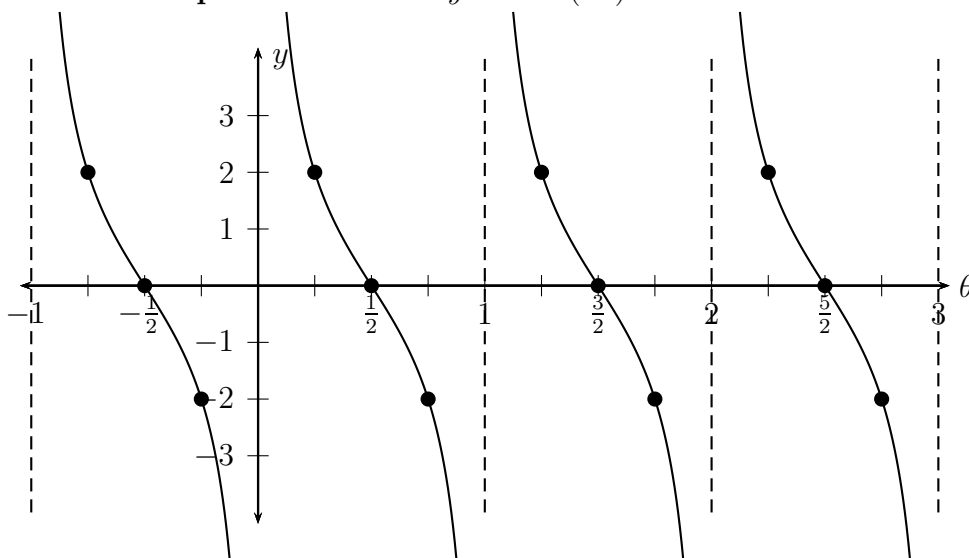

Secant and cosecant are more straight-forward to graph. $\sec \theta = \frac{1}{\cos \theta}$ so the zeros of cosine correspond with the vertical asymptotes of secant. Further, the maximum and minimum of cosine ($y = 1$ or -1) correspond to the local minimum and maximum of secant. Likewise for cosecant and sine.

Recipe for graphing $a \sec(b\theta + c)$ or $a \csc(b\theta + c)$:

1. Lightly sketch the graph of $a \cos(b\theta + c)$ (for secant) or $a \sin(b\theta + c)$ (for cosecant).
2. Draw vertical asymptotes through the zeros of the cosine or sine functions.
3. Draw smooth “U’s” following the vertical asymptotes and touching the maxima or minima of the cosine or sine functions.

Example 2.48: Sketch the graph of $y = 2 \sec(\theta)$

1. Lightly sketch the graph of $y = 2 \cos(\theta)$.

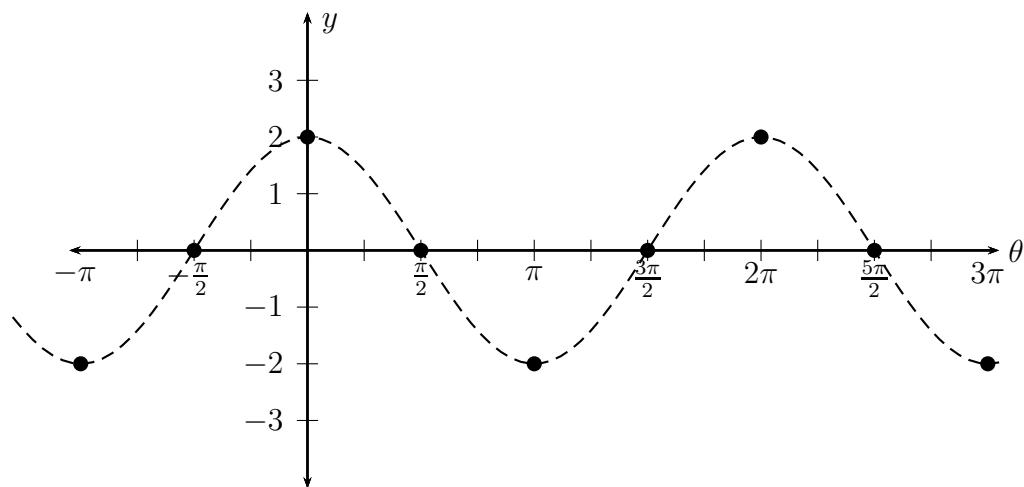

2. Draw vertical asymptotes through the zeros of $y = 2 \cos(\theta)$.

3. Draw "U's".

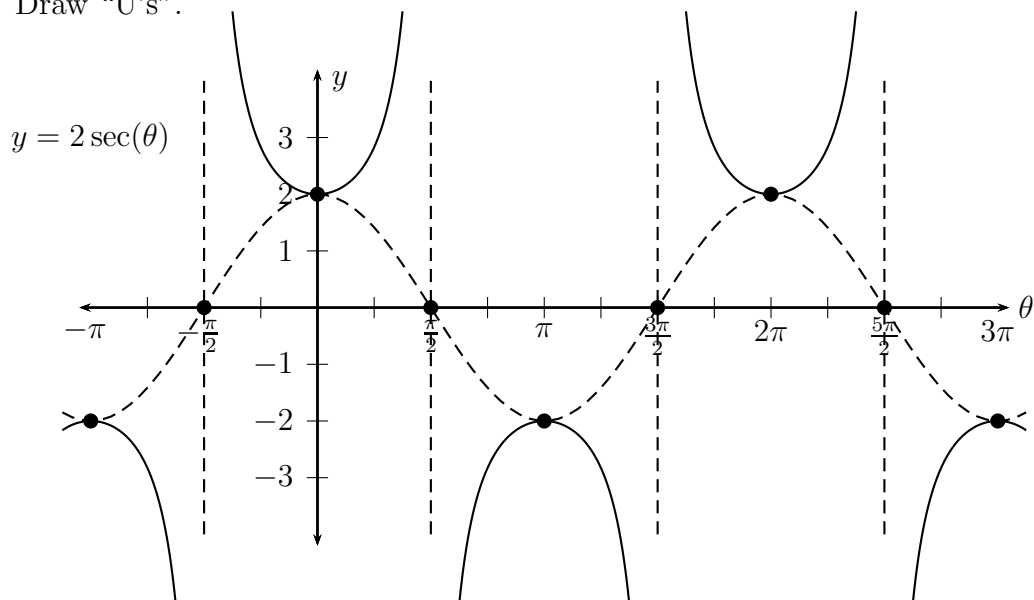

Example 2.49: Sketch the graph of $y = \csc(2\theta + \frac{\pi}{4})$

1. Lightly sketch the graph of $y = \sin(2\theta + \frac{\pi}{4})$. (Use example 2.38.)

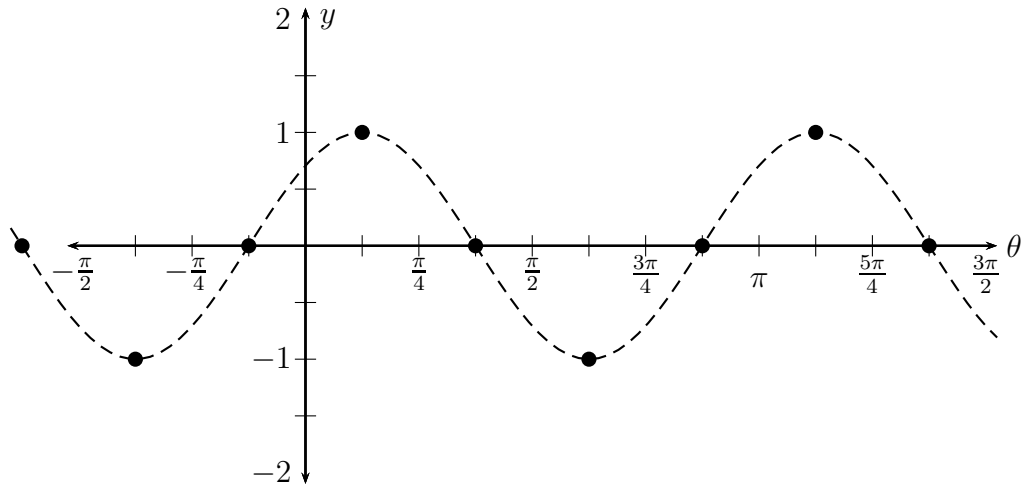

2. Draw vertical asymptotes through the zeros of $y = \sin(2\theta + \frac{\pi}{4})$.

3. Draw “U’s”.

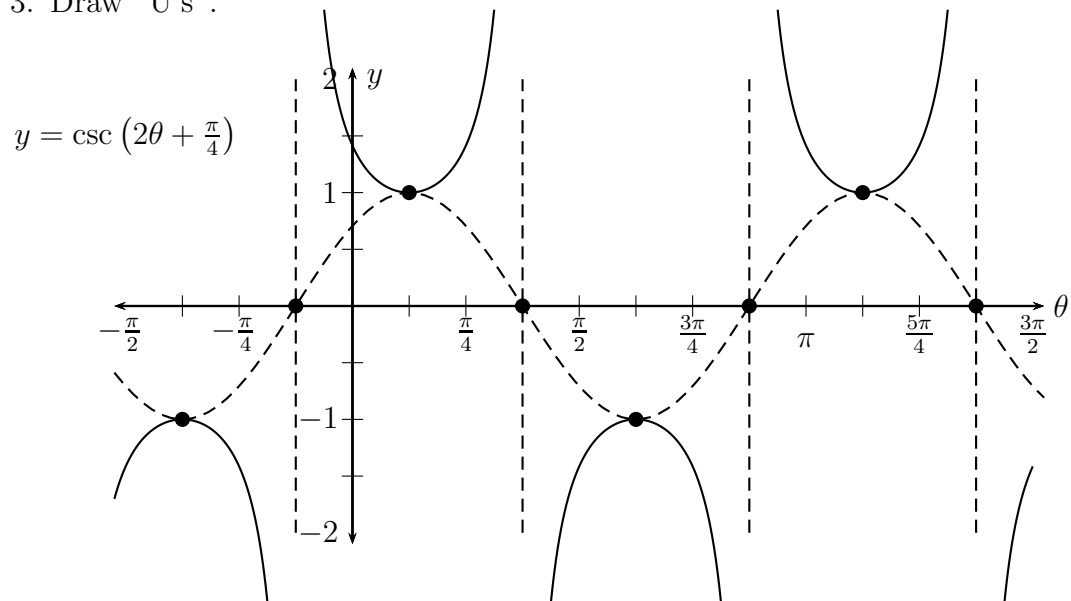

Example 2.50: Sketch the graph of $y = \frac{1}{2} \sec(\pi\theta)$

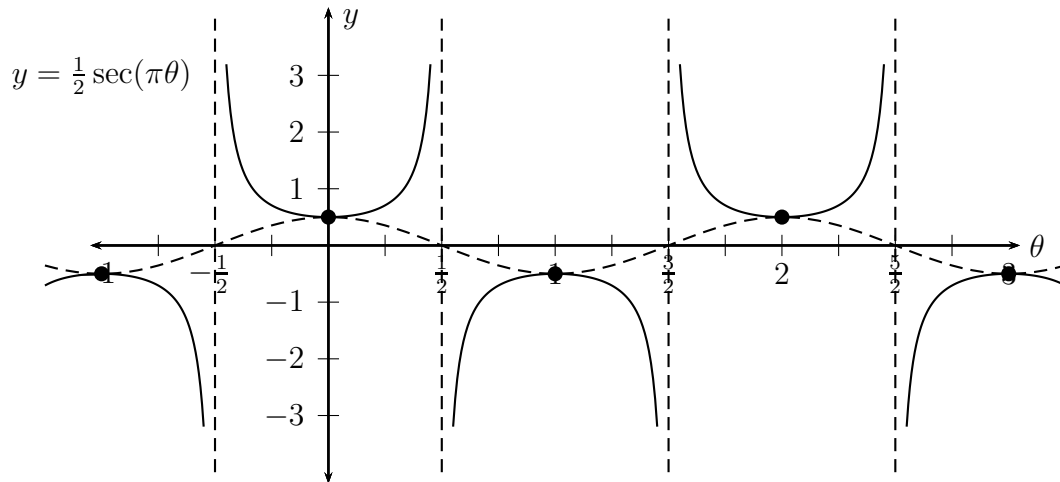

Homework 2.4

1. Sketch the graphs of the functions below.

(a)

$$y = \frac{1}{2} \tan\left(x - \frac{\pi}{4}\right)$$

(b)

$$y = -\tan(\pi x)$$

(c)

$$y = \cot\left(\frac{\pi}{2}x + \frac{\pi}{8}\right)$$

(d)

$$y = \cot\left(\frac{1}{2}x\right) + 1$$

2. Sketch the graphs of the functions below.

(a)

$$y = \sec(4x)$$

(b)

$$y = -2 \csc(2\pi x)$$

(c)

$$y = 3 \csc\left(\frac{2}{3}x - \frac{\pi}{6}\right)$$

(d)

$$y = \sec\left(\frac{1}{4}x\right) - 1$$

Further practice: Page 451 (sec 5.4) #1-46

Solutions

1. (a)

$$y = \frac{1}{2} \tan\left(x - \frac{\pi}{4}\right)$$

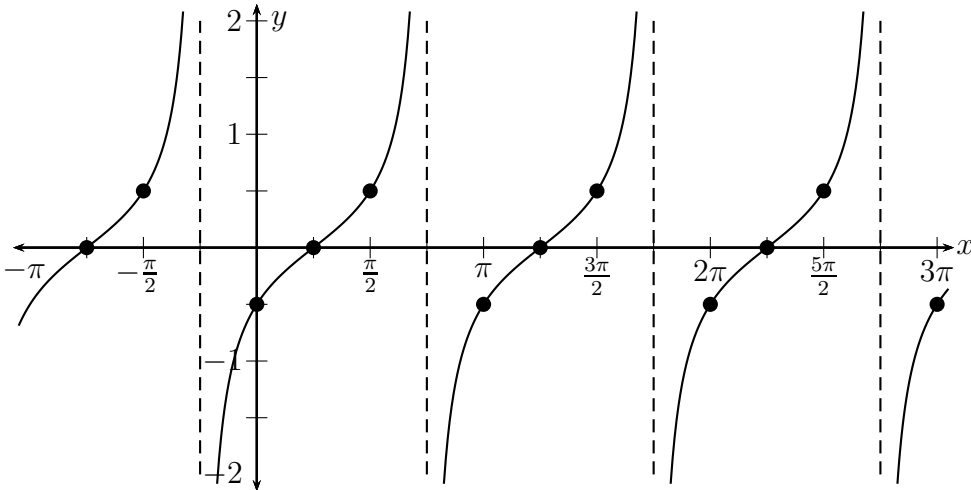

(b)

$$y = -\tan(\pi x)$$

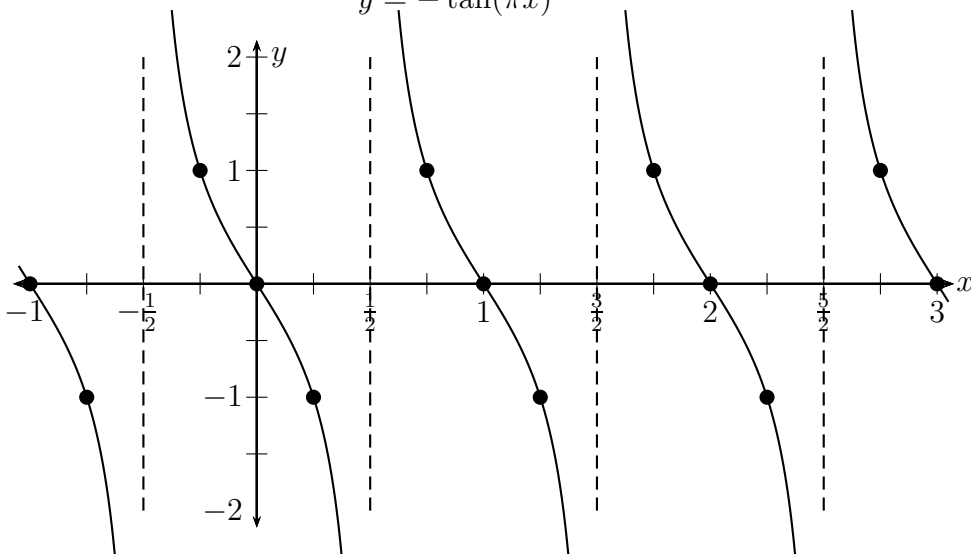

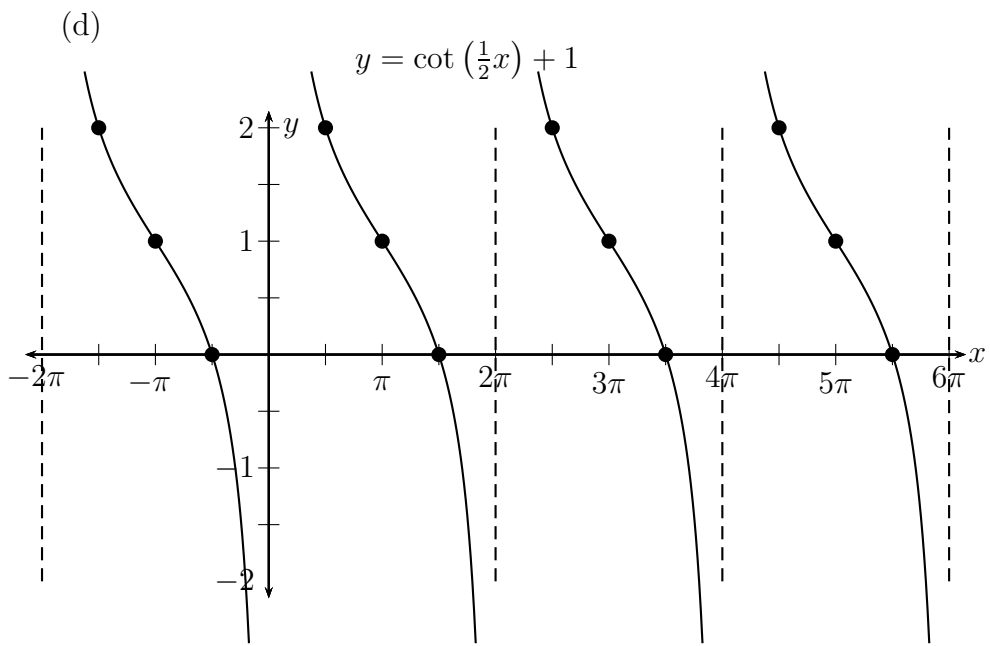
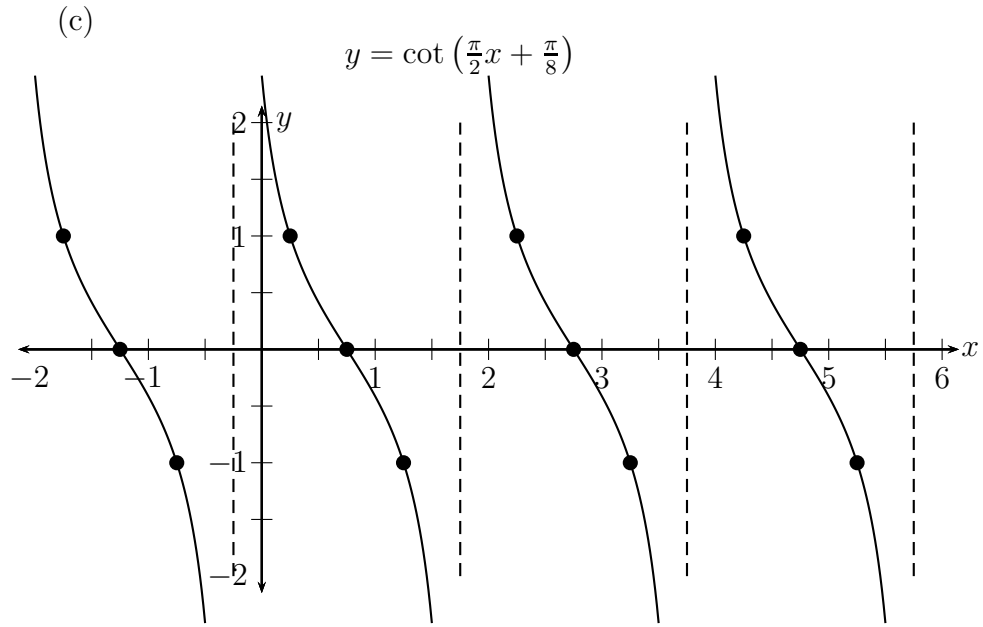

2. (a)

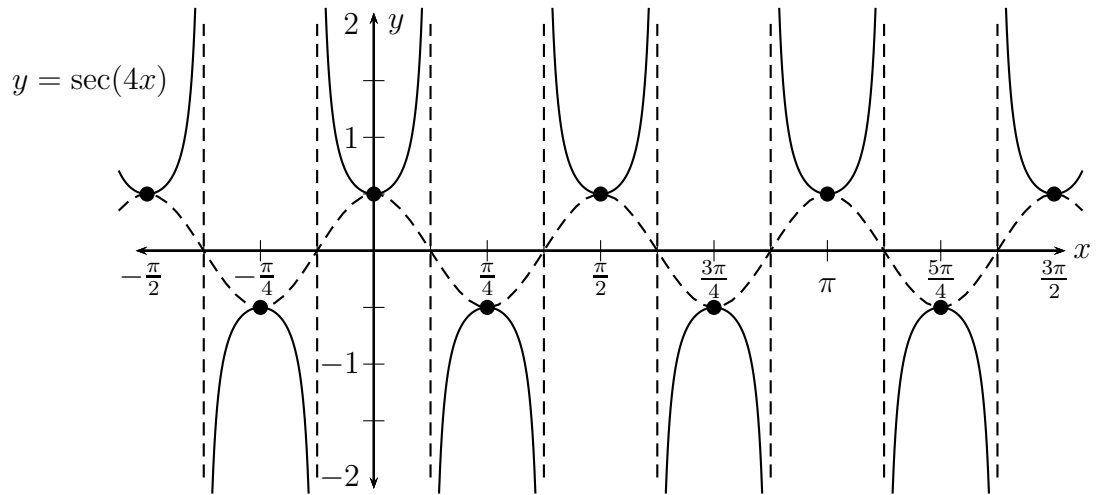

(b)

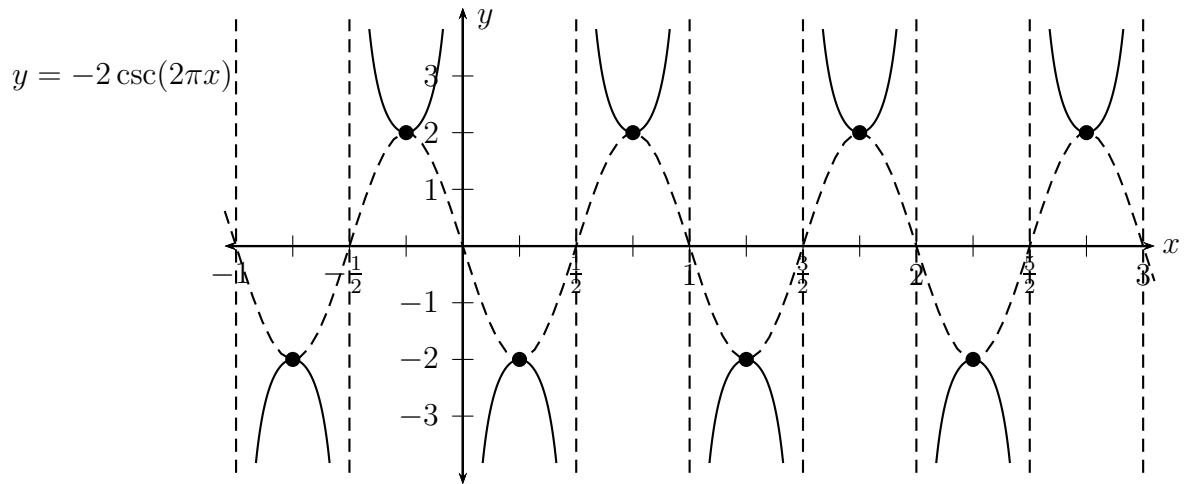

(c)

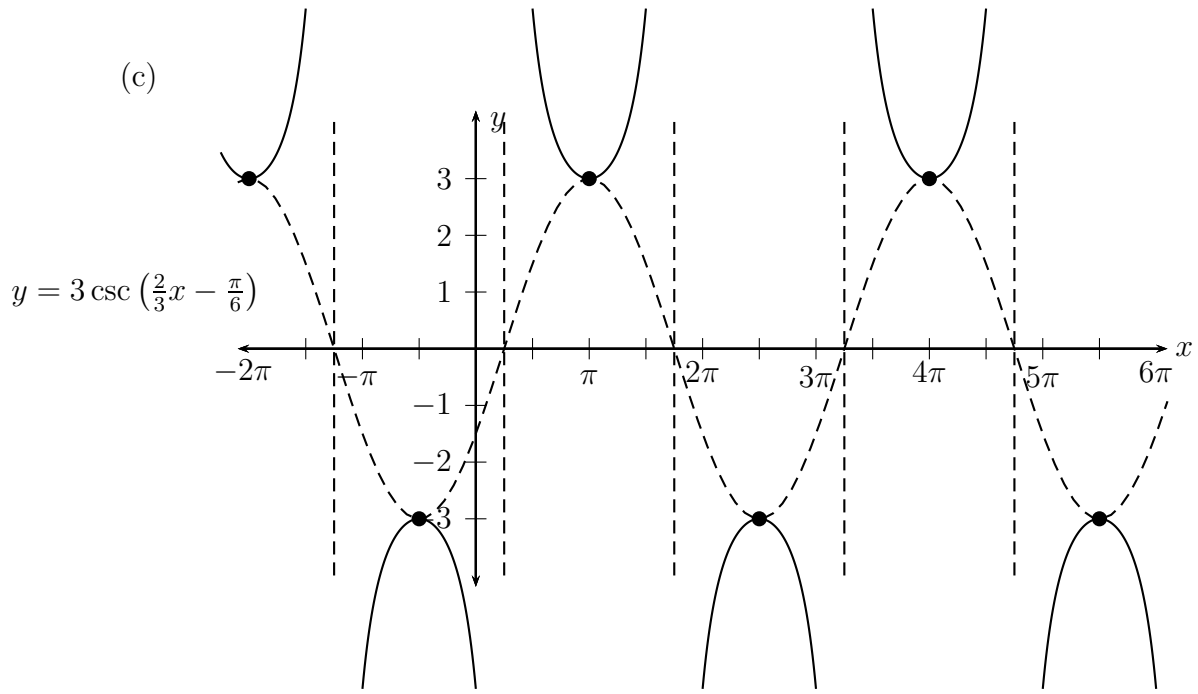

(d)

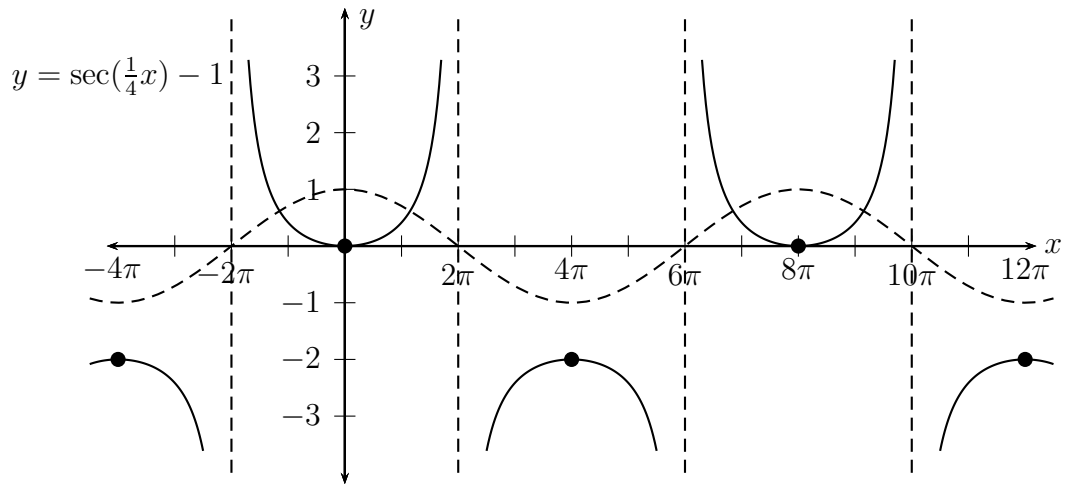

2.5 Inverse Trig Functions

2.5.1 Inverse Function Review

Say you have a function, f . The function takes values in its **domain** and returns values in its **range**. That is,

$$f : \text{Domain}(f) \rightarrow \text{Range}(f)$$

Definition: The inverse function to f , written f^{-1} , takes values in the range of f and returns values in the domain of f . That is,

$$f^{-1} : \text{Range}(f) \rightarrow \text{Domain}(f)$$

according to the rule:

$$f^{-1}(f(x)) = x \quad \text{and} \quad f(f^{-1}(y)) = y$$

Another way to think of this is the inverse function “un-does” whatever f “does”.

Example 2.51: Let $f(x) = 2x + 1$. Thus, for instance, $f(1) = 3$. So what is $f^{-1}(3) = ?$

$$f^{-1}(3) = f^{-1}(f(1)) = 1$$

f takes 1 to 3, so f^{-1} takes 3 back to 1.

What is $f^{-1}(8)$? If f takes x to 8, then $f^{-1}(8) = x$.

$$\begin{aligned} f(x) &= 8 \\ 2x + 1 &= 8 \\ x &= \frac{8-1}{2} = 3.5 \end{aligned}$$

$f(3.5) = 8$, so $f^{-1}(8) = 3.5$.

What, then, is $f^{-1}(y)$? If f takes x to y , then $f^{-1}(y) = x$.

$$\begin{aligned} f(x) &= y \\ 2x + 1 &= y \\ x &= \frac{y-1}{2} \end{aligned}$$

Thus, $f^{-1}(y) = \frac{y-1}{2}$.

Notice,

$$f(f^{-1}(y)) = f\left(\frac{y-1}{2}\right) = 2\left(\frac{y-1}{2}\right) + 1 = y - 1 + 1 = y$$

and

$$f^{-1}(f(x)) = \frac{f(x) - 1}{2} = \frac{2x + 1 - 1}{2} = \frac{2x}{2} = x$$

just as is supposed to happen.

When does f have an inverse function?

If $f(x) = x^2$ then $f(2) = 4$ and $f(-2) = 4$. So what is $f^{-1}(4) = ?$

To satisfy the conditions, $f^{-1}(4)$ must be 2 and -2. This is not possible for a function. Thus $f(x) = x^2$ **does not have** an inverse function.

f has an inverse if and only if f is **one-to-one**

Definition: f is **one-to-one** if for every $y \in \text{Range}(f)$ there is **exactly one** $x \in \text{Domain}(f)$, so that $f(x) = y$.

Equivalently, f is **one-to-one** if any horizontal line crosses the graph of f **no more than once**. This is called the **Horizontal Line Test**.

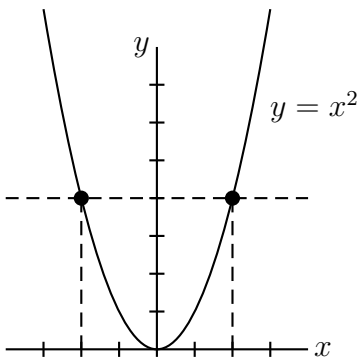

Not one-to-one.

Two x 's (2 and -2) for one y (4).

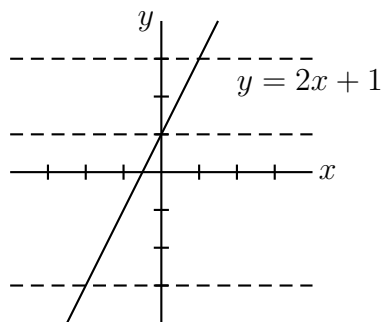

Is one-to-one.

One x for each y .

Finally, a function which is not one-to-one can be made one-to-one by throwing part of it away. This is called **restricting the domain**.

Let $g(x) = x^2$ ($x \geq 0$). The graph of g looks like:

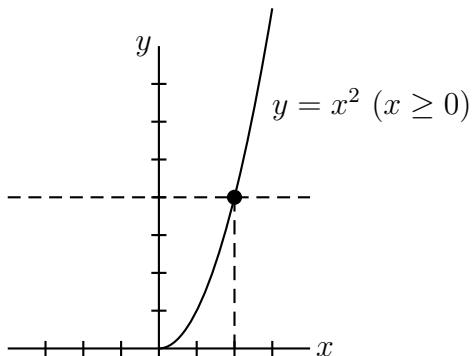

g is one-to-one.
Hence g has an inverse function.

$$g^{-1}(y) = \sqrt{y}$$

Notice,

$$g^{-1}(g(x)) = \sqrt{x^2} = |x| = x$$

2.5.2 Inverse Sine

We want to consider the inverse function for sine. However considering the graph of sine we see that it is very far from one-to-one. (In fact, it is infinite-to-one; there are infinitely many x 's for each y between -1 and 1 .)

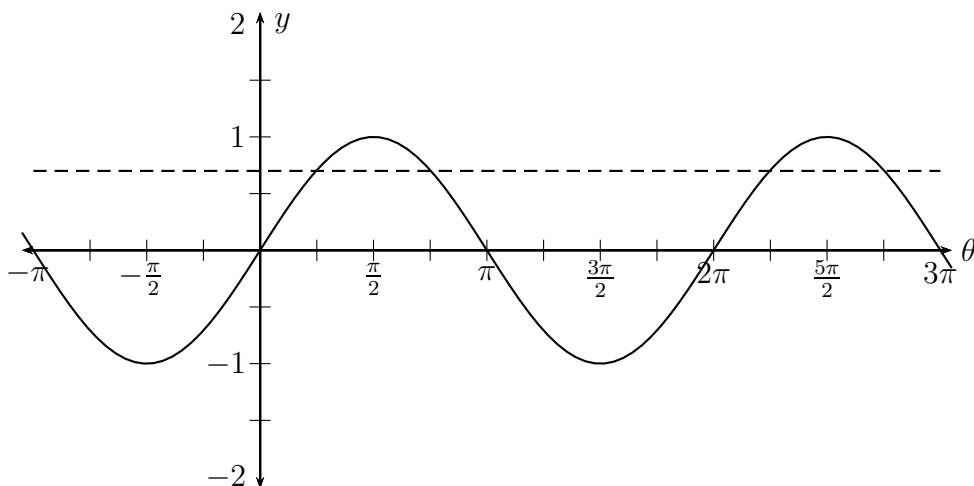

We must restrict the domain of sine so that it is one-to-one. There are many different ways to do this, but the most popular (and the one your calculator no doubt uses) is restricting sine to $[-\frac{\pi}{2}, \frac{\pi}{2}]$.

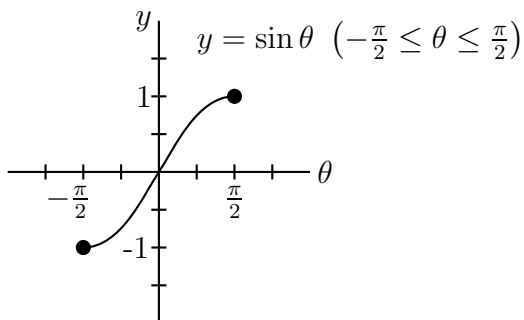

This function is one-to-one, so it has an inverse.

$$\sin^{-1} : [-1, 1] \rightarrow \left[-\frac{\pi}{2}, \frac{\pi}{2}\right]$$

Hence, inverse sine takes a number from -1 to 1 and returns an angle between $-\pi/2$ and $\pi/2$.

Example 2.52: Find $\sin^{-1}(1)$

Solution: $\sin\left(\frac{\pi}{2}\right) = 1$ and $\frac{\pi}{2}$ is between $-\pi/2$ and $\pi/2$. Thus,

$$\sin^{-1}(1) = \frac{\pi}{2}$$

Note, $\sin\left(\frac{5\pi}{2}\right) = 1$ as well, but since $\frac{5\pi}{2} > \frac{\pi}{2}$, \sin^{-1} cannot take the value $\frac{5\pi}{2}$.

Example 2.53: Find $\sin^{-1}\left(\frac{1}{\sqrt{2}}\right)$

$$\sin^{-1}\left(\frac{1}{\sqrt{2}}\right) = \frac{\pi}{4}$$

Example 2.54: Find $\sin^{-1}\left(-\frac{1}{2}\right)$

$$\sin^{-1}\left(-\frac{1}{2}\right) = -\frac{\pi}{6}$$

Example 2.55: Find $\sin\left(\sin^{-1}\left(\frac{1}{3}\right)\right)$

Solution: $\sin^{-1}\left(\frac{1}{3}\right)$ is some anonymous angle (a calculator will tell you $\approx 19.5^\circ$, but this doesn't matter). By definition \sin and \sin^{-1} cancel each other. Thus,

$$\sin\left(\sin^{-1}\left(\frac{1}{3}\right)\right) = \frac{1}{3}$$

Example 2.56: Find $\sin^{-1}\left(\sin\left(\frac{2\pi}{7}\right)\right)$

$$\sin^{-1}\left(\sin\left(\frac{2\pi}{7}\right)\right) = \frac{2\pi}{7}$$

since

$$-\frac{\pi}{2} \leq \frac{2\pi}{7} \leq \frac{\pi}{2}$$

Example 2.57: Find $\sin^{-1}(\sin(\frac{3\pi}{4}))$

Solution: The cancellation rule doesn't work here since $\frac{3\pi}{4}$ is not in the restricted domain of sine. In fact,

$$\sin^{-1}\left(\sin\left(\frac{3\pi}{4}\right)\right) = \sin^{-1}\left(\frac{1}{\sqrt{2}}\right) = \frac{\pi}{4}$$

Example 2.58: Find $\sin(\sin^{-1}(\frac{\pi}{2}))$ (Watch out for this one!!!)

Not defined since $\frac{\pi}{2} \approx 1.57 > 1$, so $\sin^{-1}(\frac{\pi}{2})$ is not defined.

Example 2.59: Find $\cos(\sin^{-1}(\frac{2}{3}))$

Solution: $\sin^{-1}(\frac{2}{3})$ is some angle; call it ϕ . Then by definition $\sin \phi = \frac{2}{3}$, and ϕ is an acute angle. Hence ϕ is the angle in the triangle:

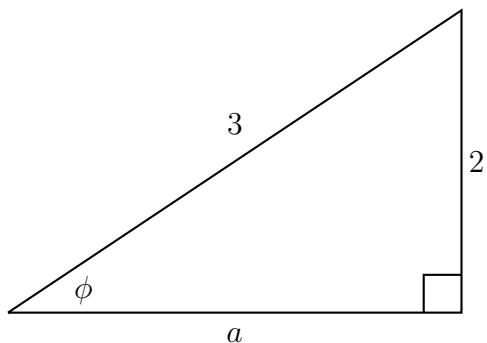

By the Pythagorean theorem,

$$a^2 + 2^2 = 3^2 \Rightarrow a = \sqrt{9 - 4} = \sqrt{5}$$

Thus,

$$\cos\left(\sin^{-1}\left(\frac{2}{3}\right)\right) = \cos(\phi) = \frac{\sqrt{5}}{3}$$

Example 2.60: Find $\cos(\sin^{-1}(x))$, when $x > 0$.

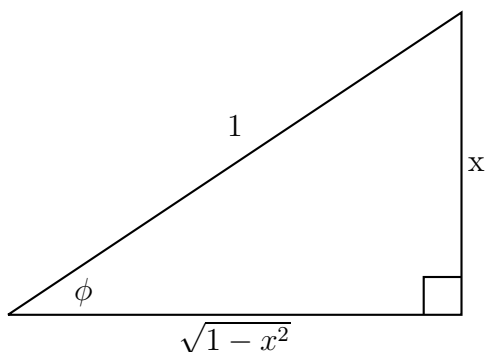

Again, $\phi = \sin^{-1}(x)$, so $\sin(\phi) = \frac{x}{1}$, and

$$\cos(\sin^{-1}(x)) = \cos(\phi) = \frac{\sqrt{1-x^2}}{1} = \sqrt{1-x^2}$$

2.5.3 Inverse Cosine

Now we consider the cosine. Like sine it is not one-to-one, so the domain must be restricted.

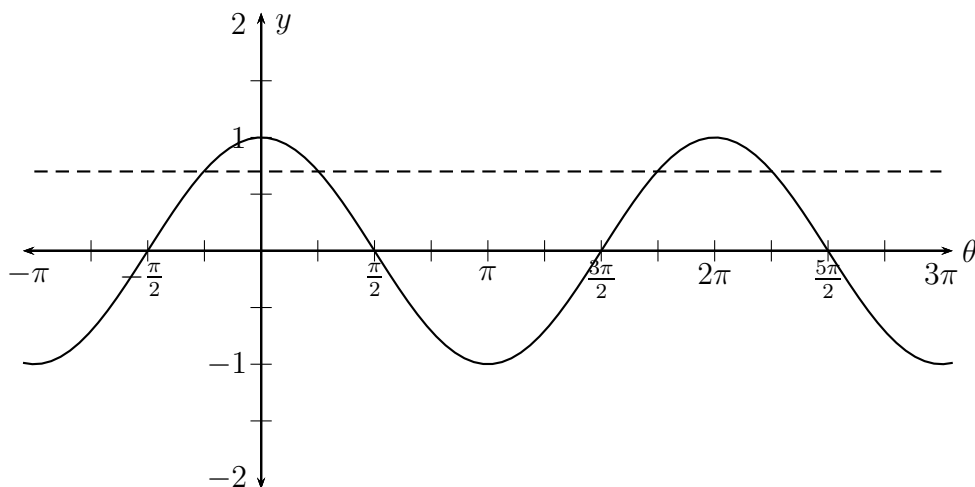

Again there are many possible restrictions, but $[-\frac{\pi}{2}, \frac{\pi}{2}]$ is **not** one of them. Cosine is not one-to-one on this interval. The natural restriction is to the interval $[0, \pi]$.

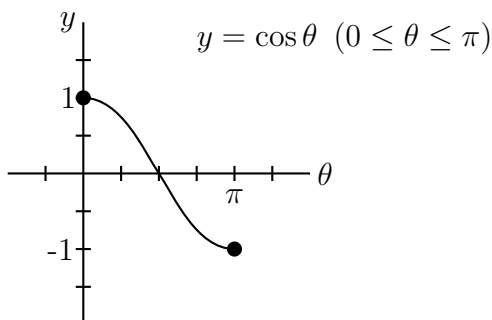

This function is one-to-one, so it has an inverse.

$$\cos^{-1} : [-1, 1] \rightarrow [0, \pi]$$

Example 2.61: Find $\cos^{-1}(0)$.

Solution: $\cos(\frac{\pi}{2}) = 0$ and $0 \leq \frac{\pi}{2} \leq \pi$, so

$$\cos^{-1}(0) = \frac{\pi}{2}$$

Note that $\cos(\frac{3\pi}{2}) = 0$, but $\frac{3\pi}{2} \notin [0, \pi]$ so $\frac{3\pi}{2}$ is not a possible value for inverse cosine.

Example 2.62: Find $\cos^{-1}(\frac{1}{2})$.

$$\cos^{-1}\left(\frac{1}{2}\right) = \frac{\pi}{3}$$

Example 2.63: Find $\cos^{-1}\left(-\frac{1}{\sqrt{2}}\right)$.

$$\cos^{-1}\left(-\frac{1}{\sqrt{2}}\right) = \frac{3\pi}{4}$$

Example 2.64: Find $\cos^{-1}\left(\cos\left(\frac{4\pi}{7}\right)\right)$.

$$\cos^{-1}\left(\cos\left(\frac{4\pi}{7}\right)\right) = \frac{4\pi}{7}$$

since $0 < \frac{4\pi}{7} < \pi$.

Example 2.65: Find $\cos^{-1}\left(\cos\left(\frac{5\pi}{4}\right)\right)$.

$$\cos^{-1}\left(\cos\left(\frac{5\pi}{4}\right)\right) = \cos^{-1}\left(-\frac{1}{\sqrt{2}}\right) = \frac{3\pi}{4}$$

Example 2.66: Find $\cos(\cos^{-1}(2))$.

Not defined since $\cos^{-1}(2)$ is not defined.

Example 2.67: Find $\tan(\cos^{-1}(\frac{3}{5}))$

Hint: Let ϕ be the angle $\cos^{-1}(\frac{3}{5})$, and draw a triangle as in example 2.59.

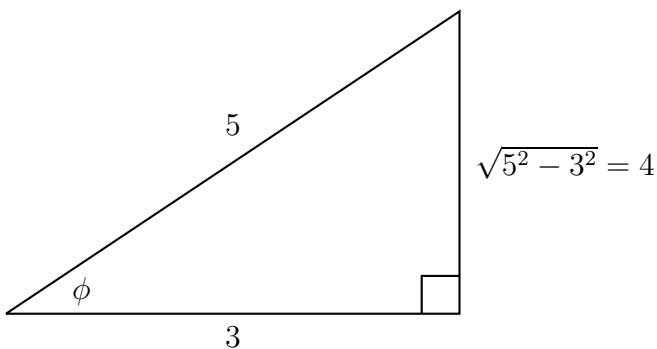

$$\cos^{-1}\left(\frac{3}{5}\right) = \frac{4}{3}$$

Example 2.68: What about $\tan(\cos^{-1}(-\frac{3}{5}))$? $-\frac{4}{3}$

Hint: In what quadrant is $\cos^{-1}(-\frac{3}{5})$? Quadrant II

What about $\sin(\cos^{-1}(-\frac{3}{5}))$? $\frac{4}{5}$ (sine is positive in quadrant II.)

2.5.4 Inverse Tangent

Like sine and cosine (and any other periodic function) tangent is not one-to-one. A glance at the graph of tangent shows there's a clear restriction to make it one-to-one: $(-\frac{\pi}{2}, \frac{\pi}{2})$.

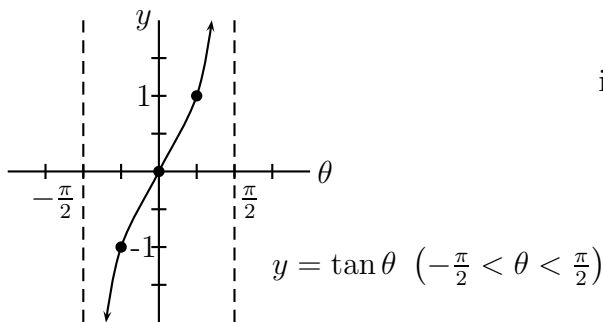

This function is one-to-one, so it has an inverse.

$$\tan^{-1} : (-\infty, \infty) \rightarrow \left(-\frac{\pi}{2}, \frac{\pi}{2}\right)$$

Example 2.69: Find $\tan^{-1}(1)$.

$$\tan^{-1}(1) = \frac{\pi}{4}$$

Example 2.70: Find $\tan^{-1}\left(-\frac{1}{\sqrt{3}}\right)$.

$$\tan^{-1}\left(-\frac{1}{\sqrt{3}}\right) = -\frac{\pi}{6}$$

Example 2.71: Find $\tan(\tan^{-1}(2))$.

$$\tan(\tan^{-1}(2)) = 2$$

Example 2.72: Find $\cos(\tan^{-1}(2))$.

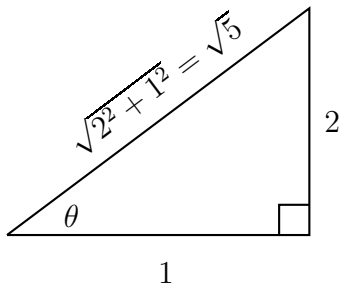

$$\tan(\theta) = \frac{2}{1}$$

$$\cos(\tan^{-1}(2)) = \cos(\theta) = \frac{1}{\sqrt{5}}$$

2.5.5 Inverse Applications

Let's end with a few easy applications of inverse functions.

Given the sides of a right triangle, how would you find the angle, θ ?

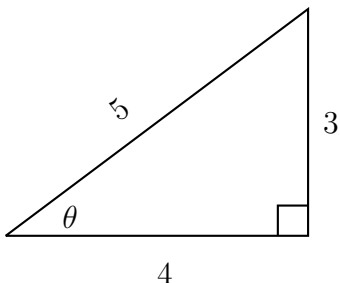

By the acute angle definition in section 2.1, $\sin \theta = \frac{3}{5}$. We're looking for an angle in the first quadrant, so there's no need to be clever. Using a calculator:

$$\theta = \sin^{-1}\left(\frac{3}{5}\right) \approx 36.9^\circ$$

Example 2.73: A six foot tall man is standing 50 feet away from a 150 foot tall building. What is the angle of elevation from the man to the top of the building?

Solution:

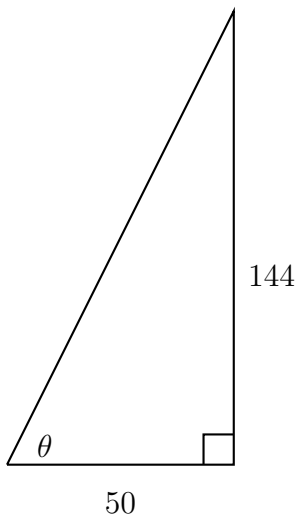

$$\tan \theta = \frac{144}{50}$$

$$\theta = \tan^{-1}\left(\frac{144}{50}\right) \approx 70.85^\circ$$

Example 2.74: A three foot tall child is flying a kite which is 25 feet in the air. The 45 foot long string connecting the child to the kite is tight and straight. What is the angle of elevation from the child to the kite?

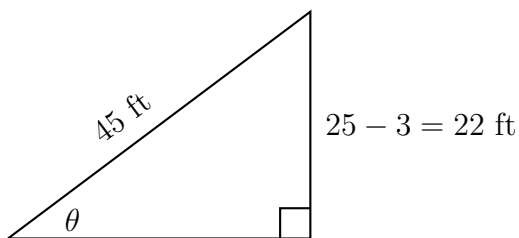

$$\theta = \sin^{-1} \left(\frac{22}{45} \right) \approx 29.3^\circ$$

Homework 2.5

1. Evaluate the inverse functions.

- (a) $\sin^{-1} \left(\frac{\sqrt{3}}{2} \right)$
- (b) $\cos^{-1} \left(\frac{\sqrt{2}}{2} \right)$
- (c) $\tan^{-1} (\sqrt{3})$
- (d) $\sin^{-1} \left(-\frac{1}{2} \right)$
- (e) $\cos^{-1} \left(-\frac{\sqrt{3}}{2} \right)$
- (f) $\tan^{-1}(-1)$

2. Evaluate the composition of functions.

- (a) $\sin \left(\sin^{-1} \left(-\frac{2}{3} \right) \right)$
- (b) $\cos \left(\cos^{-1} \left(\frac{\pi}{2} \right) \right)$
- (c) $\tan \left(\tan^{-1} \left(\frac{\pi}{2} \right) \right)$

3. Evaluate the composition of functions.

- (a) $\sin^{-1} \left(\sin \left(\frac{2\pi}{3} \right) \right)$
- (b) $\cos^{-1} \left(\cos \left(\frac{2\pi}{3} \right) \right)$
- (c) $\tan^{-1} (\tan(1))$
- (d) $\sin^{-1} \left(\sin \left(\frac{5\pi}{4} \right) \right)$
- (e) $\cos^{-1} \left(\cos \left(-\frac{\pi}{6} \right) \right)$

(f) $\tan^{-1} \left(\tan \left(\frac{4\pi}{3} \right) \right)$

4. Evaluate the composition of functions.

- (a) $\cos \left(\sin^{-1} \left(\frac{2}{3} \right) \right)$
- (b) $\tan \left(\cos^{-1} \left(\frac{5}{8} \right) \right)$
- (c) $\csc \left(\tan^{-1} \left(\frac{4}{3} \right) \right)$
- (d) $\cos \left(\sin^{-1} \left(-\frac{2}{3} \right) \right)$
- (e) $\tan \left(\cos^{-1} \left(-\frac{5}{8} \right) \right)$
- (f) $\csc \left(\tan^{-1} \left(-\frac{4}{3} \right) \right)$

5. Evaluate the composition of functions assuming $x > 0$.

- (a) $\sin(\cos^{-1}(x))$
- (b) $\tan(\cos^{-1}(x))$
- (c) $\csc(\tan^{-1}(x))$

6. A man is sitting on a 10 foot high pier holding a short fishing reel. The man hooks a fish which is two feet below the surface of the water. If he has 30 feet of tight line out, what is the angle of depression from the man to the fish?

Further practice: Page 567 (sec 7.4) #1-36,41-44,49-51

Solutions

1. (a) $\frac{\pi}{3}$, (b) $\frac{\pi}{4}$, (c) $\frac{\pi}{3}$, (d) $-\frac{\pi}{6}$, (e) $\frac{5\pi}{6}$, (f) $-\frac{\pi}{4}$

2. (a) $-\frac{2}{3}$, (b) DNE, (c) $\frac{\pi}{2}$

3. (a) $\frac{\pi}{3}$, (b) $\frac{2\pi}{3}$, (c) 1, (d) $-\frac{\pi}{4}$, (e) $\frac{\pi}{6}$, (f) $\frac{\pi}{3}$

4. (a) $\frac{\sqrt{5}}{3}$, (b) $\frac{\sqrt{39}}{5}$, (c) $\frac{5}{4}$, (d) $\frac{\sqrt{5}}{3}$, (e) $-\frac{\sqrt{39}}{5}$, (f) $\frac{-5}{4}$

5. (a) $\sqrt{1-x^2}$, (b) $\frac{\sqrt{1-x^2}}{x}$ (c) $\sqrt{1+x^2}$

6. The angle of depression (measured from the horizontal!) is about 23.6° .

2.6 Trigonometric Equations

The values of an inverse function and the solutions to an equations are often confused. The thing to remember is a function produces exactly **one value** for each input, while an equation may have many solutions.

Consider the function \sqrt{x} . For each $x \geq 0$ this function has one value.

e.g. $\sqrt{4} = 2$ and $\sqrt{25} = 5$. People who say $\sqrt{4}$ is ± 2 are badly mis-informed.

Contrast this with the solutions to the equation:

$$x^2 = 4$$

There are two values for x which make this a true statement,

$$x = 2 \text{ and } x = -2$$

hence there are two solutions. $\sqrt{4}$ gives you one solution, but there is another.

2.6.1 Simple Trigonometric Equations

Consider the equation:

$$\cos(x) = \frac{1}{2}$$

$\cos^{-1}\left(\frac{1}{2}\right) = \frac{\pi}{3}$ gives you one solution, but as we can see by looking at the graph, there are infinitely many others.

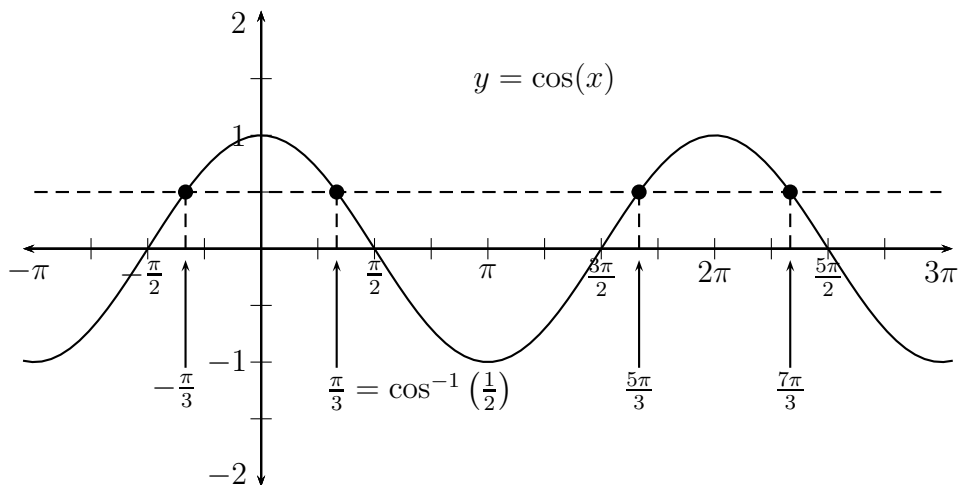

How do we find them all?

First, notice that all solutions have the same reference angle: $\frac{\pi}{3}$, and the \cos^{-1} gave it to you.

Second, notice that there are solutions in Quadrants I and IV only. This is sensible as cosine is positive only in those Quadrants.

Finally, notice that all the other angles in Quadrant I are co-terminal, and all the angles in Quadrant IV are co-terminal.

Recipe for solving $\sin(x) = y$ or $\cos(x) = y$.

1. Find the reference angle: $\text{trig}^{-1}|y|$.
2. Find the quadrant(s) of the solutions.
3. Find one solution in each quadrant, then list all angles co-terminal to it by writing: $+2\pi n$ or $+360^\circ n$.

Let's apply this recipe to the problem just discussed.

Example 2.75: Find all solutions to: $\cos(x) = \frac{1}{2}$

1. Reference angle = $\cos^{-1} \left| \frac{1}{2} \right| = \frac{\pi}{3}$
2. $\cos(x) > 0 \Rightarrow$ Quadrants I and IV
- 3.

$$\text{Quadrant I: } x = \frac{\pi}{3} + 2\pi n$$

$$\begin{aligned} \text{Quadrant IV: } x &= \left(2\pi - \frac{\pi}{3}\right) + 2\pi n \\ &= \frac{5\pi}{3} + 2\pi n \end{aligned}$$

n can be any integer. So another way to write the answer is:

$$n = \dots \quad -1 \quad 0 \quad 1 \quad 2 \quad \dots$$

$$\text{Quadrant I: } x = \dots \quad -\frac{5\pi}{3} \quad \frac{\pi}{3} \quad \frac{7\pi}{3} \quad \frac{13\pi}{3} \quad \dots$$

$$\text{Quadrant IV: } x = \dots \quad -\frac{\pi}{3} \quad \frac{5\pi}{3} \quad \frac{11\pi}{3} \quad \frac{17\pi}{3} \quad \dots$$

Example 2.76: Find all solutions to: $\sin(x) = -\frac{1}{\sqrt{2}}$

1. Reference angle = $\sin^{-1} \left(+\frac{1}{\sqrt{2}} \right) = \frac{\pi}{4}$.
2. $\sin(x) < 0 \Rightarrow$ Quadrants = III, IV
3. Quadrant III: $x = \frac{5\pi}{4} + 2\pi n$

$$\text{Quadrant IV: } x = \frac{7\pi}{4} + 2\pi n \text{ (or } -\frac{\pi}{4} + 2\pi n)$$

The recipe can be used even if the reference angle is not one of our special angles.

Example 2.77: Approximate the solutions to $\cos(x) = -0.6$

1. Reference angle = $\cos^{-1}(+0.6) \approx 53.1^\circ$
2. $\cos(x) < 0 \Rightarrow$ Quadrants = II, III
3. Quadrant II: $x \approx 126.9^\circ + 360^\circ n$
 Quadrant III: $x \approx 233.1^\circ + 360^\circ n$

The recipe can be used to solve $\tan(x) = y$ as well, but since the period of tangent is π there is an easier method. We show both methods.

Example 2.78: Find all solutions to: $\tan(x) = -1$

1. Reference angle = $\tan^{-1}|-1| = \tan^{-1}(1) = \frac{\pi}{4}$
2. $\tan(x) < 0 \Rightarrow$ Quadrants II and IV
- 3.

$$\begin{aligned} \text{Quadrant II : } x &= \left(\pi - \frac{\pi}{4}\right) + 2\pi n \\ &= \frac{3\pi}{4} + 2\pi n \end{aligned}$$

$$\begin{aligned} \text{Quadrant IV : } x &= \left(2\pi - \frac{\pi}{4}\right) + 2\pi n \\ &= \frac{7\pi}{4} + 2\pi n \end{aligned}$$

But notice how this set of solutions:

$$\begin{array}{cccccc} n = & \dots & -1 & 0 & 1 & 2 & \dots \\ \text{Quadrant II : } x = & \dots & -\frac{5\pi}{4} & \frac{3\pi}{4} & \frac{11\pi}{4} & \frac{19\pi}{4} & \dots \\ \text{Quadrant IV : } x = & \dots & -\frac{\pi}{4} & \frac{7\pi}{4} & \frac{15\pi}{4} & \frac{23\pi}{4} & \dots \end{array}$$

Is the same as this set:

$$\begin{array}{cccccc} n = & \dots & -1 & 0 & 1 & 2 & 3 & 4 & \dots \\ -\frac{\pi}{4} + \pi n : x = & \dots & -\frac{5\pi}{4} & -\frac{\pi}{4} & \frac{3\pi}{4} & \frac{7\pi}{4} & \frac{11\pi}{4} & \frac{15\pi}{4} & \dots \end{array}$$

In fact, the solution to $\tan(x) = y$ can always be written as just:

$$x = \tan^{-1}(y) + \pi n$$

2.6.2 More Complicated Trig Equations

More complicated trig equations should be first reduced to simple equations of the type we solved in the previous section.

Example 2.79: Find all solutions to: $2 \cos^2(x) - 7 \cos(x) + 3 = 0$

Solution:

The left hand side of the equation is a quadratic polynomial in cosine—which factors! Sometimes this is easier to see if we make a simple substitution, letting $y = \cos(x)$. Then,

$$\begin{aligned} 2 \cos^2(x) - 7 \cos(x) + 3 &= 0 \\ 2y^2 - 7y + 3 &= 0 \\ (2y - 1)(y - 3) &= 0 \\ \Rightarrow 2y - 1 = 0 \quad \text{or} \quad y - 3 = 0 \\ \Rightarrow y = \frac{1}{2} \quad \text{or} \quad y = 3 \end{aligned}$$

Substituting back in for y ,

$$\begin{aligned} \cos(x) = \frac{1}{2} \quad \text{or} \quad \cos(x) = 3 \\ x = \frac{\pi}{3} + 2\pi n \quad (\text{no solution}) \\ x = \frac{5\pi}{3} + 2\pi n \end{aligned}$$

(we used our solution to example 2.75)

Example 2.80: Find all solutions to: $1 + \sin(x) = 2 \cos^2(x)$.

Hint: Re-write $\cos^2(x)$ as something with $\sin^2(x)$.

From the Pythagorean Identity $\cos^2(x) = 1 - \sin^2(x)$, so substituting:

$$\begin{aligned}1 + \sin(x) &= 2(1 - \sin^2(x)) \\ \Rightarrow 2 \sin^2(x) + \sin(x) - 1 &= 0\end{aligned}$$

Letting $y = \sin(x)$,

$$\begin{aligned}2y^2 + y - 1 &= 0 \\ (2y - 1)(y + 1) &= 0 \\ \Rightarrow 2y - 1 = 0 &\text{ or } y + 1 = 0\end{aligned}$$

$$\Rightarrow y = \frac{1}{2} \text{ or } y = -1$$

$$\sin(x) = \frac{1}{2} \text{ or } \sin(x) = -1$$

$$\begin{aligned}x &= \frac{\pi}{6} + 2\pi n & x &= \frac{3\pi}{2} + 2\pi n \\ x &= \frac{5\pi}{6} + 2\pi n\end{aligned}$$

Again, we can approximate the solutions to a quadratic trig equation even if the quadratic does not factor. We just have to use the Quadratic Formula:

$$ax^2 + bx + c = 0 \quad \Rightarrow \quad x = \frac{-b \pm \sqrt{b^2 - 4ac}}{2a}$$

Example 2.81: Approximate the solutions to:

$$\cos^2(x) + 2 \cos(x) - 2 = 0$$

Solution:

The quadratic does not factor, so we appeal to the Quadratic Formula.

$$\cos(x) = \frac{-(2) \pm \sqrt{(2)^2 - 4(1)(-2)}}{2} = \frac{-2 \pm \sqrt{12}}{2} = -1 \pm \sqrt{3}$$

Thus,

$$\cos(x) = -1 + \sqrt{3} \approx 0.732 \quad \text{or} \quad \cos(x) = -1 - \sqrt{3} \approx -2.732$$

For the first equation the reference angle $\approx \cos^{-1}(0.732) \approx 42.9^\circ$, and the solutions are in Quadrants I and IV. Hence,

$$x \approx 42.9^\circ + 360^\circ n \quad \text{and} \quad x \approx 317.1^\circ + 360^\circ n$$

The second equation has no solutions.

A second type of equation also relies on solving a simpler trig equation.

Example 2.82: Find all solutions between 0 and 2π to the equation:

$$\sin(2x) = \frac{1}{2}$$

Solution: First let $\theta = 2x$ and solve:

$$\sin(\theta) = \frac{1}{2}$$

The reference angle $= \sin^{-1}\left(\frac{1}{2}\right) = \frac{\pi}{6}$, and the solutions are in Quadrants I and II, so

$$\theta = \frac{\pi}{6} + 2\pi n$$

$$\theta = \frac{5\pi}{6} + 2\pi n$$

Substituting back in for θ we have,

$$2x = \frac{\pi}{6} + 2\pi n \Rightarrow x = \frac{\pi}{12} + \pi n$$

$$2x = \frac{5\pi}{6} + 2\pi n \Rightarrow x = \frac{5\pi}{12} + \pi n$$

We get solutions between 0 and 2π for $n = 0$ or 1, thus

$$x = \frac{\pi}{12}, \frac{5\pi}{12}, \frac{13\pi}{12}, \frac{17\pi}{12}$$

Example 2.83: Find all solutions between 0 and 2π to the equation:

$$\sin(3x) = -\frac{1}{\sqrt{2}}$$

(*Hint:* Refer to example 2.76)

From example 2.76 we have that

$$3x = \frac{5\pi}{4} + 2\pi n \Rightarrow x = \frac{5\pi}{12} + \frac{2\pi n}{3} = \frac{5\pi+8\pi n}{12} = \frac{5\pi}{12}, \frac{13\pi}{12}, \frac{21\pi}{12}$$

$$3x = \frac{7\pi}{4} + 2\pi n \Rightarrow x = \frac{7\pi}{12} + \frac{2\pi n}{3} = \frac{7\pi+8\pi n}{12} = \frac{7\pi}{12}, \frac{15\pi}{12}, \frac{23\pi}{12}$$

Here $n = 0, 1,$ or 2

And, of course, we can approximate the solutions to such an equation even if it doesn't involve one of our special angles.

Example 2.84: Approximate all solutions between 0° and 360° to the equation:

$$\cos(2x) = -\frac{2}{3}$$

For $\cos(\theta) = -\frac{2}{3}$ we have the reference angle is $\cos^{-1}\left(\frac{2}{3}\right) \approx 48.2^\circ$. Thus,

$$\text{QII} : \theta = 2x = 131.8^\circ + 360^\circ n \Rightarrow x = \frac{131.8^\circ}{2} + \frac{360^\circ n}{2} \approx 65.9^\circ + 180^\circ n$$

$$\text{QIII} : \theta = 2x = 228.2^\circ + 360^\circ n \Rightarrow x = \frac{228.2^\circ}{2} + \frac{360^\circ n}{2} \approx 114.1^\circ + 180^\circ n$$

The solutions are then $x \approx 65.9^\circ, 114.1^\circ, 245.9^\circ, \text{ or } 294.1^\circ$.

Homework 2.6

1. Find all solutions of the equations below. Give exact answers in radians. (b)

(a) $2 \sin(x) + 1 = 0$

(b) $2 \cos(x) + \sqrt{3} = 0$

(c) $\tan(x) = \sqrt{3}$

$$\cos(x) = -\frac{1}{2}\sqrt{2 + \sqrt{2}}$$

(c)

2. Use the triangle below to find all solutions of the equations below. Give exact answers in radians.

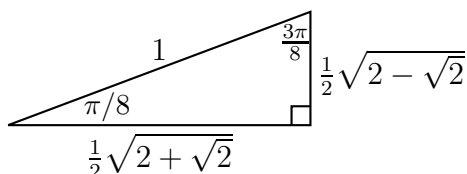

(a)

$$\sin(x) = \frac{1}{2}\sqrt{2 + \sqrt{2}}$$

3. Use your calculator to approximate all solutions of the equations below. Give answers to one decimal place in degrees.

(a) $\sin(x) = 0.3$

(b) $\cos(x) = -0.7$

(c) $\tan(x) = -\sqrt{2}$

4. Find all solutions of the equations below. Give exact answers in radians. (a)

(a) $4 \cos^2(x) - 1 = 0$

(b) $2 \sin^2(x) = 1 + \sin(x)$

(c) $\sec^2(x) = 1 + \tan(x)$ (b)

(d) $\tan^4(x) - 9 = 0$

$$\sin(4x) = \frac{1}{\sqrt{2}}$$

5. Use your calculator to approximate all solutions of the equations below. Give answers to one decimal place in degrees.

(a) $3 \sin^2(x) - 7 \sin(x) + 2 = 0$

(b) $\cos^2(x) + 4 \cos(x) + 1 = 0$

$$\cos(3x) = -\frac{\sqrt{3}}{2}$$

7. Use your calculator to approximate all solutions of the equations below between 0° and 360° . Give answers to one decimal place in degrees.

6. Find all solutions of the equations below between 0 and 2π . Give exact answers in radians.

(a) $\sin(3x) = 0.3$

(b) $\cos(2x) = -0.7$

Further practice: Page 579 (sec 7.5) #1-33,39-41,47-49,51,53,54

Solutions

- (a) $\frac{7\pi}{6} + 2\pi n$ or $\frac{11\pi}{6} + 2\pi n$, (b) $\frac{7\pi}{6} + 2\pi n$ or $\frac{5\pi}{6} + 2\pi n$ (c) $\frac{\pi}{3} + \pi n$
- (a) $\frac{3\pi}{8} + 2\pi n$, $\frac{5\pi}{8} + 2\pi n$ (b) $\frac{7\pi}{8} + 2\pi n$, $\frac{9\pi}{8} + 2\pi n$ (c) $\frac{5\pi}{8} + \pi n$
- (a) $17.5^\circ + 360^\circ n$ or $162.5^\circ + 360^\circ n$, (b) $134.4^\circ + 360^\circ n$ or $225.6^\circ + 360^\circ n$, (c) $-54.7^\circ + 180^\circ n$
- (a) $x = \frac{\pi}{4} + \pi n$ or $x = -\frac{\pi}{4} + \pi n$, (b) $x = \frac{\pi}{2} + 2\pi n$ or $x = \frac{7\pi}{6} + 2\pi n$ or $x = \frac{11\pi}{6} + 2\pi n$, (c) $x = 0 + \pi n = \pi n$ or $x = \frac{\pi}{4} + \pi n$, (d) $x = \frac{\pi}{3} + \pi n$ or $x = \frac{-\pi}{3} + \pi n$
- (a) $x = 19.5^\circ + 360^\circ n$ or $x = 160.5^\circ + 360^\circ n$, (b) $x = 105.5^\circ + 360^\circ n$ or $x = 254.5^\circ + 360^\circ n$
- (a) $x = \frac{\pi}{16} + \frac{\pi}{2}n$ or $x = \frac{3\pi}{16} + \frac{\pi}{2}n$,
 Inside the unit circle we have solutions: $\frac{\pi}{16}, \frac{9\pi}{16}, \frac{17\pi}{16}, \frac{25\pi}{16}, \frac{3\pi}{16}, \frac{11\pi}{16}, \frac{19\pi}{16}, \frac{27\pi}{16}$
 (b) $x = \frac{5\pi}{18} + \frac{2\pi}{3}n$ or $x = \frac{7\pi}{18} + \frac{2\pi}{3}n$,
 Inside the unit circle we have solutions: $\frac{5\pi}{18}, \frac{17\pi}{18}, \frac{29\pi}{18}, \frac{7\pi}{18}, \frac{19\pi}{18}, \frac{31\pi}{18}$
- (a) $54.2^\circ, 174.2^\circ, 294.2^\circ, 5.8^\circ, 125.8^\circ, 245.8^\circ$
 (b) $67.2^\circ, 247.2^\circ, 112.8^\circ, 292.8^\circ$

Chapter 3

Formulas

3.1 Identities

An equation is just a mathematical statement. It may be always true, always false, or true only for certain values of the variables. If an equation is true only for some values of the variables, we call it a **conditional equation**, and the values which make it true the **solutions** to the equation. Of course such equations are very important, and you've been trained to solve them since you were small. But there are the other kinds of equations.

An equation that is always false is called a **contradiction**.

An equation that is always true is called an **identity**.

$2x - 1 = 5$ is a conditional equation since it is a true statement only if $x = 3$.

$x + 4 = x$ is a contradiction since it is not true for any value of x .

$x - \frac{1}{x} = \frac{(x+1)(x-1)}{x}$ **appears** to be an identity since it is true for various values of x .

$$x = 2 \Rightarrow 2 - \frac{1}{2} = \frac{3}{2} = \frac{(2+1)(2-1)}{2}$$

$$x = 1 \Rightarrow 1 - \frac{1}{1} = 0 = \frac{(1+1)(1-1)}{1}$$

$$x = 10 \Rightarrow 10 - \frac{1}{10} = 9.9 = \frac{(10+1)(10-1)}{10}$$

But this just shows it's true for those three x 's. How do we show it's true for **all** x 's?

You **cannot** just treat it like a conditional equation. To begin, choose one side of the equation: the Left Hand Side of the equation (LHS) or the Right Hand Side (RHS). Then you do algebra to that expression until it looks like the other side.

Example 3.1: Prove the following is an identity.

$$x - \frac{1}{x} = \frac{(x+1)(x-1)}{x}$$

Solution: We'll start with the Left Hand Side.

$$\begin{aligned} \text{LHS} &= x - \frac{1}{x} \\ &= \frac{x^2}{x} - \frac{1}{x} \\ &= \frac{x^2-1}{x} \\ &= \frac{(x+1)(x-1)}{x} = \text{RHS} \end{aligned}$$

Notice we did not do anything like “solve” the equation. We did not “multiply both sides by x ” as there are no “both sides”. There's one side (the starting point) and the other side (the destination).

Remember, too, that we already have several identities, and that they can be used to prove new identities. The most important identity we have is $\sin^2 x + \cos^2 x = 1$.

Example 3.2: Prove the following is an identity.

$$\sec(x) = \tan(x) + \frac{\cos(x)}{1 + \sin(x)}$$

Solution: It usually easier to start with the more complicated side and simplify. Let's start with the Right Hand Side.

$$\begin{aligned} \text{RHS} &= \tan(x) + \frac{\cos(x)}{1+\sin(x)} \\ &= \frac{\sin(x)}{\cos(x)} + \frac{\cos(x)}{1+\sin(x)} \\ &= \frac{\sin(x)}{\cos(x)} \left(\frac{1+\sin(x)}{1+\sin(x)} \right) + \frac{\cos(x)}{1+\sin(x)} \left(\frac{\cos(x)}{\cos(x)} \right) \\ &= \frac{\sin(x)+\sin^2(x)+\cos^2(x)}{\cos(x)(1+\sin(x))} \\ &= \frac{\sin(x)+1}{\cos(x)(1+\sin(x))} \\ &= \frac{1}{\cos(x)} = \sec(x) = \text{LHS} \end{aligned}$$

Example 3.3: Prove the following is an identity.

$$\frac{\sec^2(x) - 1}{\sec^2(x)} = \sin^2(x)$$

$$\begin{aligned} \text{LHS} &= \frac{\sec^2(x) - 1}{\sec^2(x)} \\ &= \frac{\sec^2(x)}{\sec^2(x)} - \frac{1}{\sec^2(x)} \\ &= 1 - \frac{1}{\left(\frac{1}{\cos^2(x)}\right)} \\ &= 1 - \cos^2(x) \\ &= \sin^2(x) \\ &= \text{RHS} \end{aligned}$$

Example 3.4: Prove the following is an identity.

$$\frac{\cos(-x) + \sin(-x)}{\cos(x)} = 1 - \tan(x)$$

$$\begin{aligned} \text{LHS} &= \frac{\cos(-x) + \sin(-x)}{\cos(x)} \\ &= \frac{\cos(x) - \sin(x)}{\cos(x)} \\ &= \frac{\cos(x)}{\cos(x)} - \frac{\sin(x)}{\cos(x)} \\ &= 1 - \tan(x) \\ &= \text{RHS} \end{aligned}$$

One trick that often works when you have a $1 \pm \sin(x)$ or $1 \pm \cos(x)$ is to multiply by the “conjugate” $1 \mp \sin(x)$ or $1 \mp \cos(x)$.

Example 3.5: Prove the following is an identity.

$$\frac{\cos(x)}{1 - \sin(x)} = \sec(x) + \tan(x)$$

Solution:

$$\begin{aligned} \text{LHS} &= \frac{\cos(x)}{1 - \sin(x)} \\ &= \frac{\cos(x)}{1 - \sin(x)} \left(\frac{1 + \sin(x)}{1 + \sin(x)} \right) \\ &= \frac{\cos(x)(1 + \sin(x))}{1 - \sin^2(x)} \\ &= \frac{\cos(x)(1 + \sin(x))}{\cos^2(x)} \\ &= \frac{1 + \sin(x)}{\cos(x)} \\ &= \frac{1}{\cos(x)} + \frac{\sin(x)}{\cos(x)} \\ &= \sec(x) + \tan(x) \\ &= \text{RHS} \end{aligned}$$

Homework 3.1

Prove the identities.

1. $(\cos(x) + \sin(x))^2 = 1 + 2 \cos(x) \sin(x)$

2. $\cos^2(\theta)(1 + \tan^2(\theta)) = 1$

3. $\csc(x) - \sin(x) = \cos(x) \cot(x)$

4. $\cos(t) + \tan(t) \sin(t) = \sec(t)$

5. $\cot(-x) \cos(-x) + \sin(-x) = -\csc(x)$

6. $\frac{1 - \cos(\alpha)}{\sin(\alpha)} = \frac{\sin(\alpha)}{1 + \cos(\alpha)}$

7. $\tan^2(t) - \sin^2(t) = \tan^2(t) \sin^2(t)$

8. $\frac{1}{\sec(t) + \tan(t)} + \frac{1}{\sec(t) - \tan(t)} = 2 \sec(t)$

Further practice: Page 540 (sec 7.1) #1-84

Solutions

1.

$$\begin{aligned}\text{LHS} &= (\cos(x) + \sin(x))^2 \\ &= \cos^2(x) + 2\cos(x)\sin(x) + \sin^2(x) \\ &= 1 + 2\cos(x)\sin(x) \\ &= \text{RHS}\end{aligned}$$

2.

$$\begin{aligned}\text{LHS} &= \cos^2(\theta)(1 + \tan^2(\theta)) \\ &= \cos^2(\theta) \left(1 + \frac{\sin^2(\theta)}{\cos^2(\theta)}\right) \\ &= \cos^2(\theta) + \cos^2(\theta) \frac{\sin^2(\theta)}{\cos^2(\theta)} \\ &= \cos^2(\theta) + \sin^2(\theta) \\ &= 1 \\ &= \text{RHS}\end{aligned}$$

3.

$$\begin{aligned}\text{LHS} &= \csc(x) - \sin(x) \\ &= \frac{1}{\sin(x)} - \sin(x) \\ &= \frac{1}{\sin(x)} - \sin(x) \frac{\sin(x)}{\sin(x)} \\ &= \frac{1 - \sin^2(x)}{\sin(x)} \\ &= \frac{\cos^2(x)}{\sin(x)} \\ &= \cos(x) \frac{\cos(x)}{\sin(x)} \\ &= \cos(x) \cot(x) \\ &= \text{RHS}\end{aligned}$$

4.

$$\begin{aligned}\text{LHS} &= \cos(t) + \tan(t) \sin(t) \\ &= \cos(t) + \frac{\sin(t)}{\cos(t)} \sin(t) \\ &= \cos(t) \frac{\cos(t)}{\cos(t)} + \frac{\sin^2(t)}{\cos(t)} \\ &= \frac{\cos^2(t) + \sin^2(t)}{\cos(t)} \\ &= \frac{1}{\cos(t)} \\ &= \sec(t) \\ &= \text{RHS}\end{aligned}$$

5.

$$\begin{aligned}
 \text{LHS} &= \cot(-x) \cos(-x) + \sin(-x) \\
 &= \frac{\cos(-x)}{\sin(-x)} \cos(-x) + \sin(-x) \\
 &= \frac{\cos(x)}{-\sin(x)} \cos(x) - \sin(x) \\
 &= -\frac{\cos^2(x)}{\sin(x)} - \sin(x) \frac{\sin(x)}{\sin(x)} \\
 &= -\frac{\cos^2(x)}{\sin(x)} - \frac{\sin^2(x)}{\sin(x)} \\
 &= -\frac{(\cos^2(x) + \sin^2(x))}{\sin(x)} \\
 &= -\frac{1}{\sin(x)} \\
 &= -\csc(x) \\
 &= \text{RHS}
 \end{aligned}$$

6.

$$\begin{aligned}
 \text{LHS} &= \frac{1 - \cos(\alpha)}{\sin(\alpha)} \\
 &= \frac{1 - \cos(\alpha)}{\sin(\alpha)} \left(\frac{1 + \cos(\alpha)}{1 + \cos(\alpha)} \right) \\
 &= \frac{1 - \cos^2(\alpha)}{\sin(\alpha)(1 + \cos(\alpha))} \\
 &= \frac{\sin^2(\alpha)}{\sin(\alpha)(1 + \cos(\alpha))} \\
 &= \frac{\sin(\alpha)}{1 + \cos(\alpha)} \\
 &= \text{RHS}
 \end{aligned}$$

7.

$$\begin{aligned}
 \text{LHS} &= \tan^2(t) - \sin^2(t) \\
 &= \left(\frac{\sin(t)}{\cos(t)} \right)^2 - \sin^2(t) \\
 &= \frac{\sin^2(t)}{\cos^2(t)} - \sin^2(t) \left(\frac{\cos^2(t)}{\cos^2(t)} \right) \\
 &= \frac{\sin^2(t) - \sin^2(t) \cos^2(t)}{\cos^2(t)} \\
 &= \frac{\sin^2(t)(1 - \cos^2(t))}{\cos^2(t)} \\
 &= \sin^2(t) \frac{\sin^2(t)}{\cos^2(t)} \\
 &= \sin^2(t) \tan^2(t) \\
 &= \text{RHS}
 \end{aligned}$$

8.

$$\begin{aligned}
 \text{LHS} &= \frac{1}{\sec(t) + \tan(t)} + \frac{1}{\sec(t) - \tan(t)} \\
 &= \frac{1}{\sec(t) + \tan(t)} \left(\frac{\sec(t) - \tan(t)}{\sec(t) - \tan(t)} \right) + \frac{1}{\sec(t) - \tan(t)} \left(\frac{\sec(t) + \tan(t)}{\sec(t) + \tan(t)} \right) \\
 &= \frac{\sec(t) - \tan(t)}{\sec^2(t) - \tan^2(t)} + \frac{\sec(t) + \tan(t)}{\sec^2(t) - \tan^2(t)} \\
 &= \frac{\sec(t) - \tan(t) + \sec(t) + \tan(t)}{\sec^2(t) - \tan^2(t)} \\
 &= \frac{2 \sec(t)}{\sec^2(t) - \tan^2(t)} \\
 &= \frac{1}{\sec(t)} \\
 &= \text{RHS}
 \end{aligned}$$

3.2 Sum and Difference Formulas

Most functions do not “distribute” over a sum. That is, for most functions f , and most numbers, x and y ,

$$f(x + y) \neq f(x) + f(y)$$

Certainly,

$$(x + y)^2 \neq x^2 + y^2$$

and

$$\ln(x + y) \neq \ln(x) + \ln(y)$$

Likewise, for most angles α and β ,

$$\cos(\alpha + \beta) \neq \cos(\alpha) + \cos(\beta) \text{ and } \sin(\alpha + \beta) \neq \sin(\alpha) + \sin(\beta)$$

For instance,

$$\cos\left(\frac{\pi}{4} + \frac{\pi}{4}\right) = \cos\left(\frac{\pi}{2}\right) = 0$$

but

$$\cos\left(\frac{\pi}{4}\right) + \cos\left(\frac{\pi}{4}\right) = \frac{1}{\sqrt{2}} + \frac{1}{\sqrt{2}} = \sqrt{2} \neq 0$$

There is, however, a way to write $\cos(\alpha + \beta)$ in terms of the sine and cosine of α and β . It's more complicated than just “distributing”, but it has the advantage of being true.

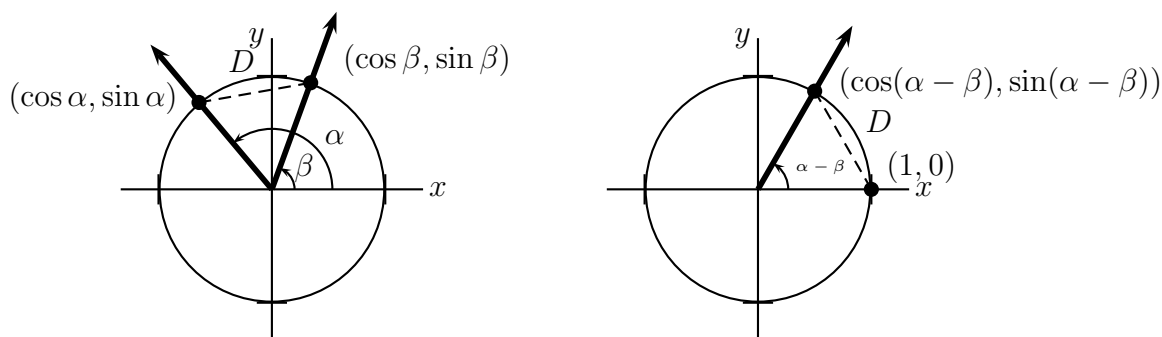

The **Distance Formula** for the distance between two points, (x_1, y_1) and (x_2, y_2) , is:

$$D = \sqrt{(x_1 - x_2)^2 + (y_1 - y_2)^2}$$

The square of the distance in the left picture is:

$$\begin{aligned} D^2 &= (\cos \alpha - \cos \beta)^2 + (\sin \alpha - \sin \beta)^2 \\ &= \cos^2 \alpha - 2 \cos \alpha \cos \beta + \cos^2 \beta + \sin^2 \alpha - 2 \sin \alpha \sin \beta + \sin^2 \beta \\ &= (\cos^2 \alpha + \sin^2 \alpha) + (\cos^2 \beta + \sin^2 \beta) - 2(\cos \alpha \cos \beta + \sin \alpha \sin \beta) \\ &= 2 - 2(\cos \alpha \cos \beta + \sin \alpha \sin \beta) \end{aligned}$$

The square of the distance in the right picture is:

$$\begin{aligned}D^2 &= (\cos(\alpha - \beta) - 1)^2 + (\sin(\alpha - \beta) - 0)^2 \\&= \cos^2(\alpha - \beta) - 2\cos(\alpha - \beta) + 1 + \sin^2(\alpha - \beta) \\&= 2 - 2\cos(\alpha - \beta)\end{aligned}$$

Setting the two expressions for D^2 equal:

$$\begin{aligned}2 - 2\cos(\alpha - \beta) &= 2 - 2(\cos\alpha\cos\beta + \sin\alpha\sin\beta) \\ \cos(\alpha - \beta) &= \cos\alpha\cos\beta + \sin\alpha\sin\beta\end{aligned}$$

This expression can be used to derive other expressions for the sine or cosine of the sum or difference of angles.

$$\boxed{\cos(\alpha \pm \beta) = \cos\alpha\cos\beta \mp \sin\alpha\sin\beta}$$

$$\boxed{\sin(\alpha \pm \beta) = \sin\alpha\cos\beta \pm \cos\alpha\sin\beta}$$

Example 3.6: Find the exact value of $\cos\left(\frac{\pi}{12}\right)$.

Solution: First notice that $\frac{\pi}{12} = \frac{\pi}{3} - \frac{\pi}{4}$.

Then,

$$\begin{aligned}\cos\left(\frac{\pi}{12}\right) &= \cos\left(\frac{\pi}{3} - \frac{\pi}{4}\right) \\&= \cos\left(\frac{\pi}{3}\right)\cos\left(\frac{\pi}{4}\right) + \sin\left(\frac{\pi}{3}\right)\sin\left(\frac{\pi}{4}\right) \\&= \frac{1}{2}\frac{\sqrt{2}}{2} + \frac{\sqrt{3}}{2}\frac{\sqrt{2}}{2} \\&= \frac{\sqrt{2}+\sqrt{6}}{4}\end{aligned}$$

Example 3.7: Find the exact value of $\sin\left(\frac{17\pi}{12}\right)$.

Hint: $\frac{17\pi}{12} = \frac{8\pi}{12} + \frac{9\pi}{12} = \frac{2\pi}{3} + \frac{3\pi}{4}$

$$\begin{aligned}\sin\left(\frac{17\pi}{12}\right) &= \sin\left(\frac{2\pi}{3} + \frac{3\pi}{4}\right) \\&= \sin\left(\frac{2\pi}{3}\right)\cos\left(\frac{3\pi}{4}\right) + \cos\left(\frac{2\pi}{3}\right)\sin\left(\frac{3\pi}{4}\right) \\&= \frac{\sqrt{3}}{2}\left(-\frac{\sqrt{2}}{2}\right) + \left(-\frac{1}{2}\right)\frac{\sqrt{2}}{2} \\&= \frac{-\sqrt{6}-\sqrt{2}}{4}\end{aligned}$$

Example 3.8: Find the exact value of: $\cos 20^\circ \cos 50^\circ + \sin 20^\circ \sin 50^\circ$.
Working backwards from the difference formula for cosine,

$$\begin{aligned}\cos \alpha \cos \beta + \sin \alpha \sin \beta &= \cos(\alpha - \beta) \\ \cos 20^\circ \cos 50^\circ + \sin 20^\circ \sin 50^\circ &= \cos(20^\circ - 50^\circ) \\ &= \cos(-30^\circ) \\ &= \frac{1}{2}\end{aligned}$$

Example 3.9: Simplify the expression: $\cos\left(x + \frac{\pi}{2}\right)$.

Solution:

$$\begin{aligned}\cos\left(x + \frac{\pi}{2}\right) &= \cos(x) \cos \frac{\pi}{2} - \sin(x) \sin \frac{\pi}{2} \\ &= \cos(x) \cdot 0 - \sin(x) \cdot 1 \\ &= -\sin(x)\end{aligned}$$

Example 3.10: Simplify the expression: $\sin(x - \pi)$.

$$\begin{aligned}\sin(x - \pi) &= \sin(x) \cos \pi - \cos(x) \sin \pi \\ &= \sin(x) \cdot (-1) - \cos(x) \cdot 0 \\ &= -\sin(x)\end{aligned}$$

We can use the sum and difference rules for sine and cosine to construct similar rules for tangent.

$$\begin{aligned}\tan(\alpha \pm \beta) &= \frac{\sin(\alpha \pm \beta)}{\cos(\alpha \pm \beta)} \\ &= \frac{\sin \alpha \cos \beta \pm \cos \alpha \sin \beta}{\cos \alpha \cos \beta \mp \sin \alpha \sin \beta} \\ &= \frac{\sin \alpha \cos \beta \pm \cos \alpha \sin \beta}{\cos \alpha \cos \beta \mp \sin \alpha \sin \beta} \left(\frac{\frac{1}{\cos \alpha \cos \beta}}{\frac{1}{\cos \alpha \cos \beta}} \right)\end{aligned}$$

$\tan(\alpha \pm \beta) = \frac{\tan \alpha \pm \tan \beta}{1 \mp \tan \alpha \tan \beta}$
--

Example 3.11: Find the exact value of $\tan\left(\frac{5\pi}{12}\right)$.

First note that $\frac{5\pi}{12} = \frac{2\pi}{12} + \frac{3\pi}{12} = \frac{\pi}{6} + \frac{\pi}{4}$

$$\begin{aligned}\tan\left(\frac{5\pi}{12}\right) &= \frac{\tan\left(\frac{\pi}{6}\right) + \tan\left(\frac{\pi}{4}\right)}{1 - \tan\left(\frac{\pi}{6}\right)\tan\left(\frac{\pi}{4}\right)} \\ &= \frac{\frac{1}{\sqrt{3}} + 1}{1 - \frac{1}{\sqrt{3}} \cdot 1} \cdot \left(\frac{\sqrt{3}}{\sqrt{3}}\right) \\ &= \frac{1 + \sqrt{3}}{\sqrt{3} - 1}\end{aligned}$$

3.2.1 Writing a Sum as a Single Function

One very useful application of the sum and difference rules is to write a sum of a sine and a cosine as a single trig function, say a sine.

Example 3.12: Write $-\sin(x) + \sqrt{3}\cos(x)$ in the form: $k \sin(x + \phi)$.

Solution: We want to find k and ϕ so that

$$k \sin(x + \phi) = -\sin(x) + \sqrt{3}\cos(x)$$

We begin by letting $k = \sqrt{(-1)^2 + (\sqrt{3})^2} = 2$.

Dividing both sides of the above equation by k gives,

$$\sin(x + \phi) = -\frac{1}{2}\sin(x) + \frac{\sqrt{3}}{2}\cos(x)$$

Now applying the addition rule for sine,

$$\cos \phi \sin(x) + \sin \phi \cos(x) = -\frac{1}{2}\sin(x) + \frac{\sqrt{3}}{2}\cos(x)$$

We need to choose a ϕ so that,

$$\cos \phi = -\frac{1}{2} \text{ and } \sin \phi = \frac{\sqrt{3}}{2}$$

Cosine is negative while sine is positive, so ϕ is in quadrant II. The reference angle for ϕ is clearly $\pi/3$, hence $\phi = 2\pi/3$.

$$-\sin(x) + \sqrt{3}\cos(x) = 2 \sin\left(x + \frac{2\pi}{3}\right)$$

In general, to write $A \sin(x) + B \cos(x)$ as $k \sin(x + \phi)$,

1. Let $k = \sqrt{A^2 + B^2}$.

2. Find ϕ so that:

$$\cos \phi = \frac{A}{k} \text{ and } \sin \phi = \frac{B}{k}$$

by finding the quadrant and reference angle for ϕ .

Example 3.13: Write $\sin(x) - \cos(x)$ in the form: $k \sin(x + \phi)$.

Since $A = 1$ and $B = -1$, $k = \sqrt{1^2 + (-1)^2} = \sqrt{2}$. Then we want a ϕ so that

$$\cos \phi = \frac{1}{\sqrt{2}} \text{ and } \sin \phi = -\frac{1}{\sqrt{2}}$$

The reference angle is then,

$$\text{ref} = \cos^{-1}\left(\frac{1}{\sqrt{2}}\right) = \sin^{-1}\left(+\frac{1}{\sqrt{2}}\right) = \frac{\pi}{4}$$

Since $\cos \phi > 0$ and $\sin \phi < 0$ we know ϕ is in Quadrant IV, so $\phi = \frac{7\pi}{4}$ (or $-\frac{\pi}{4}$). Thus,

$$\sin(x) - \cos(x) = \sqrt{2} \sin\left(x + \frac{7\pi}{4}\right)$$

Example 3.14: Find k and approximate ϕ so that:

$$3 \sin(x) + 4 \cos(x) = k \sin(x + \phi)$$

$$k = \sqrt{3^2 + 4^2} = 5$$

We want a ϕ so that

$$\cos \phi = \frac{3}{5} \text{ and } \sin \phi = \frac{4}{5}$$

The reference angle is then $\cos^{-1}(3/5) \approx 53.1^\circ$. Both sine and cosine are positive, so ϕ is in Quadrant I and equal to the reference angle. Thus,

$$3 \sin(x) + 4 \cos(x) = 5 \sin(x + 53.1^\circ)$$

Homework 3.2, 3.2.1

1. Use the addition and subtraction formulas to find the exact value of the expression.

- (a) $\cos(15^\circ)$
- (b) $\sin\left(\frac{19\pi}{12}\right)$
- (c) $\tan\left(\frac{17\pi}{12}\right)$

2. Use the addition and subtraction formulas to find the exact value of the expression.

- (a) $\sin(18^\circ)\cos(27^\circ) + \cos(18^\circ)\sin(27^\circ)$
- (b) $\cos(10^\circ)\cos(80^\circ) - \sin(10^\circ)\sin(80^\circ)$
- (c)

$$\frac{\tan\left(\frac{\pi}{18}\right) + \tan\left(\frac{\pi}{9}\right)}{1 - \tan\left(\frac{\pi}{18}\right)\tan\left(\frac{\pi}{9}\right)}$$

3. Use the addition and subtraction formulas to simplify the expression.

- (a) $\sin\left(x - \frac{\pi}{2}\right)$
- (b) $\cos\left(x + \frac{3\pi}{2}\right)$
- (c) $\tan\left(\frac{\pi}{2} - x\right)$
- (d) $\sin\left(\cos^{-1}\left(\frac{1}{3}\right) + \cos^{-1}\left(\frac{3}{5}\right)\right)$

4. Prove the identities.

(a)

$$\cos\left(x + \frac{\pi}{6}\right) + \sin\left(x - \frac{\pi}{3}\right) = 0$$

(b)

$$\cos(x + y) + \cos(x - y) = 2\cos(x)\cos(y)$$

5. Write the expression exactly as $k\sin(x + \phi)$.

- (a) $\sin(x) + \cos(x)$
- (b) $-5\sin(\pi x) - 5\cos(\pi x)$
- (c) $3\sin(x) - 3\sqrt{3}\cos(x)$

6. Approximate the expression as $k\sin(x + \phi)$.

- (a) $5\sin(x) + 12\cos(x)$
- (b) $-4\sin(x) + 3\cos(x)$
- (c) $-8\sin(x) - 7\cos(x)$

Further practice: Page 548 (sec 7.2) #1-44

Solutions

1. (a) $\frac{\sqrt{6} + \sqrt{2}}{4}$, (b) $\frac{-\sqrt{2} - \sqrt{6}}{4}$, (c) $\frac{\sqrt{3} + 1}{\sqrt{3} - 1}$

2. (a) $\frac{\sqrt{2}}{2}$, (b) 0, (c) $\frac{1}{\sqrt{3}}$

3. (a) $-\cos(x)$, (b) $\sin(x)$, (c) $\cot(x)$, (d) $\frac{\sqrt{8}}{5} - \frac{4}{15}$

4. (a)

$$\begin{aligned} \text{LHS} &= \cos\left(x + \frac{\pi}{6}\right) + \sin\left(x - \frac{\pi}{3}\right) \\ &= \cos(x) \cos\left(\frac{\pi}{6}\right) - \sin(x) \sin\left(\frac{\pi}{6}\right) + \sin(x) \cos\left(\frac{\pi}{3}\right) - \cos(x) \sin\left(\frac{\pi}{3}\right) \\ &= \cos(x) \frac{\sqrt{3}}{2} - \sin(x) \frac{1}{2} + \sin(x) \frac{1}{2} - \cos(x) \frac{\sqrt{3}}{2} \\ &= 0 = \text{RHS} \end{aligned}$$

(b)

$$\begin{aligned} \text{LHS} &= \cos(x + y) + \cos(x - y) \\ &= \cos(x) \cos(y) - \sin(x) \sin(y) + \cos(x) \cos(y) + \sin(x) \sin(y) \\ &= 2 \cos(x) \cos(y) = \text{RHS} \end{aligned}$$

5. (a) $y = \sqrt{2} \sin\left(x + \frac{\pi}{4}\right)$, (b) $y = 5\sqrt{2} \sin\left(\pi x + \frac{5\pi}{4}\right)$, (c) $y = 6 \sin\left(x - \frac{\pi}{3}\right)$

6. (a) $y \approx 13 \sin(x + 67.4^\circ)$, (b) $y \approx 5 \sin(x + 143.1^\circ)$, (c) $y \approx 10.63 \sin(x + 228.8^\circ)$

3.2.2 Product-to-sum and Sum-to-product Formulas

We can also use the sum and difference formulas to write the product of two trig functions as a sum.

$$\begin{array}{r} \sin(\alpha - \beta) = \sin \alpha \cos \beta - \cos \alpha \sin \beta \\ + \quad \sin(\alpha + \beta) = \sin \alpha \cos \beta + \cos \alpha \sin \beta \\ \hline \sin(\alpha - \beta) + \sin(\alpha + \beta) = 2 \sin \alpha \cos \beta \end{array}$$

Dividing both sides by 2 we have a formula for $\sin \alpha \cos \beta$. Similarly we may derive formulas for the other products:

$$\sin \alpha \cos \beta = \frac{1}{2}(\sin(\alpha - \beta) + \sin(\alpha + \beta))$$

$$\sin \alpha \sin \beta = \frac{1}{2}(\cos(\alpha - \beta) - \cos(\alpha + \beta))$$

$$\cos \alpha \cos \beta = \frac{1}{2}(\cos(\alpha - \beta) + \cos(\alpha + \beta))$$

Example 3.15: Write $\sin(2x) \cos(3x)$ as a sum of two trig functions.

Solution: According to our first product-to-sum formula:

$$\begin{aligned} \sin(2x) \cos(3x) &= \frac{1}{2}(\sin(2x - 3x) + \sin(2x + 3x)) \\ &= \frac{1}{2}(\sin(-x) + \sin(5x)) \\ &= \frac{1}{2}(-\sin(x) + \sin(5x)) \\ &= \frac{1}{2}(\sin(5x) - \sin(x)) \end{aligned}$$

Example 3.16: Write $\sin(7x) \sin(3x)$ as a sum of two trig functions.

$$\begin{aligned} \sin(7x) \sin(3x) &= \frac{1}{2}(\cos(7x - 3x) - \cos(7x + 3x)) \\ &= \frac{1}{2}(\cos(4x) - \cos(10x)) \end{aligned}$$

Using a simple substitution we can go from a product back to a sum.

$$\text{Let } \begin{array}{l} u = \alpha - \beta \\ v = \alpha + \beta \end{array} \Rightarrow \alpha = \frac{u+v}{2}, \quad \beta = \frac{-u+v}{2} = -\frac{u-v}{2}$$

Hence our formulas become:

$$\boxed{\sin(u) + \sin(v) = 2 \sin\left(\frac{u+v}{2}\right) \cos\left(\frac{u-v}{2}\right)}$$

$$\boxed{\sin(u) - \sin(v) = 2 \cos\left(\frac{u+v}{2}\right) \sin\left(\frac{u-v}{2}\right)}$$

$$\boxed{\cos(u) - \cos(v) = -2 \sin\left(\frac{u+v}{2}\right) \sin\left(\frac{u-v}{2}\right)}$$

$$\boxed{\cos(u) + \cos(v) = 2 \cos\left(\frac{u+v}{2}\right) \cos\left(\frac{u-v}{2}\right)}$$

Example 3.17: Write $\cos(4a) - \cos(6a)$ as a product of trig functions.

$$\begin{aligned} \cos(4a) - \cos(6a) &= -2 \sin\left(\frac{4a+6a}{2}\right) \sin\left(\frac{4a-6a}{2}\right) \\ &= -2 \sin(5a) \sin(-a) \\ &= 2 \sin(5a) \sin(a) \end{aligned}$$

Example 3.18: Find the exact value of: $\sin\left(\frac{5\pi}{12}\right) + \sin\left(\frac{\pi}{12}\right)$.

$$\begin{aligned} \sin\left(\frac{5\pi}{12}\right) + \sin\left(\frac{\pi}{12}\right) &= 2 \sin\left(\frac{\frac{5\pi}{12} + \frac{\pi}{12}}{2}\right) \cos\left(\frac{\frac{5\pi}{12} - \frac{\pi}{12}}{2}\right) \\ &= 2 \sin\left(\frac{\pi}{4}\right) \cos\left(\frac{\pi}{6}\right) \\ &= 2 \left(\frac{\sqrt{2}}{2}\right) \left(\frac{\sqrt{3}}{2}\right) = \frac{\sqrt{6}}{2} \end{aligned}$$

3.2.3 Double Angle Formulas

Just as functions don't, in general, "distribute" over sums; you also cannot, in general, "factor out" a number from inside a function.

$$e^{2x} \neq 2e^x \quad \text{and} \quad \sqrt{2x} \neq 2\sqrt{x}$$

Likewise for the trig functions. As we saw in section 2.3,

$$\sin(2x) \neq 2\sin(x) \quad \text{and} \quad \cos(2x) \neq 2\cos(x)$$

We can easily use the sum and difference formulas to give us formulas for the sine or cosine of twice an angle.

$$\sin(x + x) = \sin(x)\cos(x) + \cos(x)\sin(x)$$

Thus,

$$\boxed{\sin(2x) = 2\sin(x)\cos(x)}$$

Likewise for cosine,

$$\cos(x + x) = \cos(x)\cos(x) - \sin(x)\sin(x) = \cos^2(x) - \sin^2(x)$$

Using the formula, $\cos^2(x) + \sin^2(x) = 1$ we can form three different expressions for the cosine of double an angle.

$$\boxed{\begin{aligned}\cos(2x) &= \cos^2(x) - \sin^2(x) \\ &= 2\cos^2(x) - 1 \\ &= 1 - 2\sin^2(x)\end{aligned}}$$

Example 3.19: Use a double angle formula to evaluate: $\sin\left(\frac{2\pi}{3}\right)$.

Solution:

$$\begin{aligned}\sin\left(\frac{2\pi}{3}\right) &= 2\sin\left(\frac{\pi}{3}\right)\cos\left(\frac{\pi}{3}\right) \\ &= 2 \cdot \frac{\sqrt{3}}{2} \cdot \frac{1}{2} \\ &= \frac{\sqrt{3}}{2}\end{aligned}$$

Which we know is correct by the methods of section 2.2.

Example 3.20: Use a double angle formula to evaluate: $\cos\left(\frac{2\pi}{3}\right)$.

$$\begin{aligned}\cos\left(\frac{2\pi}{3}\right) &= 2\cos^2\left(\frac{\pi}{3}\right) - 1 \\ &= 2 \cdot \left(\frac{1}{2}\right)^2 - 1 \\ &= -\frac{1}{2}\end{aligned}$$

Example 3.21: Prove the identity:

$$\frac{\cos(2\theta)}{\sin(2\theta)} = \frac{1}{2}(\cot \theta - \tan \theta)$$

$$\begin{aligned}\text{LHS} &= \frac{\cos(2\theta)}{\sin(2\theta)} \\ &= \frac{\cos^2 \theta - \sin^2 \theta}{2 \sin \theta \cos \theta} \\ &= \frac{\cos^2 \theta}{2 \sin \theta \cos \theta} - \frac{\sin^2 \theta}{2 \sin \theta \cos \theta} \\ &= \frac{1}{2} \frac{\cos \theta}{\sin \theta} - \frac{1}{2} \frac{\sin \theta}{\cos \theta} \\ &= \frac{1}{2}(\cot \theta - \tan \theta) = \text{RHS}\end{aligned}$$

Example 3.22: Simplify the expression: $\sin\left(2 \sin^{-1}\left(\frac{2}{3}\right)\right)$

Solution:

$$\begin{aligned}\sin\left(2 \sin^{-1}\left(\frac{2}{3}\right)\right) &= 2 \sin\left(\sin^{-1}\left(\frac{2}{3}\right)\right) \cos\left(\sin^{-1}\left(\frac{2}{3}\right)\right) \\ &= 2 \left(\frac{2}{3}\right) \left(\frac{\sqrt{5}}{3}\right) \\ &= \frac{4\sqrt{5}}{9}\end{aligned}$$

(Using example 2.67.)

Example 3.23: Say θ is an angle in quadrant IV, and $\cos \theta = \frac{1}{4}$. Find $\sin(2\theta)$.

Solution: To find $\sin(2\theta)$ we need both the cosine and sine of θ .

$$\begin{aligned}\sin^2 \theta + \cos^2 \theta &= 1 \\ \Rightarrow \sin \theta &= \pm \sqrt{1 - \cos^2 \theta} \\ \sin \theta &= -\sqrt{1 - \left(\frac{1}{4}\right)^2} \\ &= -\frac{\sqrt{15}}{4}\end{aligned}$$

(Negative since θ is in quadrant IV where sine is negative.)

Thus,

$$\begin{aligned}\sin(2\theta) &= 2 \sin(\theta) \cos(\theta) \\ &= 2 \cdot -\frac{\sqrt{15}}{4} \cdot \frac{1}{4} \\ &= -\frac{\sqrt{15}}{8}\end{aligned}$$

Example 3.24: Say θ is an angle in quadrant IV, and $\cos \theta = \frac{1}{4}$. Find $\cos(2\theta)$. In what quadrant is the angle 2θ ?

$$\begin{aligned}\cos(2\theta) &= 2 \cos^2(\theta) - 1 \\ &= 2 \cdot \left(\frac{1}{4}\right)^2 - 1 \\ &= -\frac{7}{8}\end{aligned}$$

Since both $\sin(2\theta) < 0$ and $\cos(2\theta) < 0$ we know 2θ is in quadrant III.

We may also use the double angle formulas to help us solve an equation.

Example 3.25: Solve the equation.

$$\sin(2x) = \cos(x)$$

Solution:

Using the double angle formula for sine we have

$$2 \sin(x) \cos(x) = \cos(x)$$

$$2 \sin(x) \cos(x) - \cos(x) = 0$$

$$\cos(x)(2 \sin(x) - 1) = 0$$

$$\Rightarrow \cos(x) = 0 \quad \text{or} \quad \sin(x) = \frac{1}{2}$$

$$\Rightarrow x = \frac{\pi}{2} + \pi n, \quad x = \frac{\pi}{6} + 2\pi n, \quad \text{or} \quad x = \frac{5\pi}{6} + 2\pi n$$

3.2.4 Half Angle Formulas

To reverse this process, going from the sine or cosine of an angle to the sine or cosine of **half** the angle, we make a simple substitution: $u = 2x$.

$$\cos(2x) = 2 \cos^2(x) - 1$$

$$\cos(u) = 2 \cos^2\left(\frac{u}{2}\right) - 1$$

Solving for the cosine of half u gives:

$$\boxed{\cos\left(\frac{u}{2}\right) = \pm \sqrt{\frac{1 + \cos(u)}{2}}}$$

Likewise,

$$\cos(2x) = 1 - 2 \sin^2(x)$$

$$\cos(u) = 1 - 2 \sin^2\left(\frac{u}{2}\right)$$

$$\boxed{\sin\left(\frac{u}{2}\right) = \pm \sqrt{\frac{1 - \cos(u)}{2}}}$$

In both cases the \pm is determined by the **quadrant of $u/2$** (not u).

Example 3.26: Use a half angle formula to find the exact value of $\sin \frac{\pi}{8}$.

Solution:

$$\begin{aligned}\sin \frac{\pi}{8} &= \sin \left(\frac{\pi/4}{2} \right) = +\sqrt{\frac{1-\cos \frac{\pi}{4}}{2}} \\ &= \sqrt{\frac{1-\frac{\sqrt{2}}{2}}{2}} \cdot \left(\frac{2}{2} \right) \\ &= \sqrt{\frac{2-\sqrt{2}}{4}} = \frac{1}{2}\sqrt{2-\sqrt{2}}\end{aligned}$$

The + comes from the fact that $\pi/8$ is in quadrant I (where sine is positive).

Example 3.27: Use a half angle formula to find the exact value of $\sin \frac{7\pi}{12}$.
(*Hint:* Watch out for the signs!)

$$\begin{aligned}\sin \frac{7\pi}{12} &= \sin \left(\frac{7\pi/6}{2} \right) = +\sqrt{\frac{1-\cos \frac{7\pi}{6}}{2}} \\ &= \sqrt{\frac{1-\frac{-\sqrt{3}}{2}}{2}} \cdot \left(\frac{2}{2} \right) \\ &= \sqrt{\frac{2+\sqrt{3}}{4}} = \frac{1}{2}\sqrt{2+\sqrt{3}}\end{aligned}$$

Notice that the outermost sign is “+” since $\frac{7\pi}{12}$ is in **quadrant II** where sine is positive. The sign of the cosine **inside** the root is “-” since $\frac{7\pi}{6}$ is in **quadrant III**.

Example 3.28: Say θ satisfies $\pi \leq \theta \leq 2\pi$ and $\cos \theta = \frac{2}{3}$.
Find $\cos \frac{\theta}{2}$ and $\sin \frac{\theta}{2}$.

Solution: First find the quadrant that $\theta/2$ is in. Dividing through by 2,

$$\pi \leq \theta \leq 2\pi \quad \Rightarrow \quad \frac{\pi}{2} \leq \frac{\theta}{2} \leq \pi$$

Thus $\theta/2$ is in Quadrant II. Cosine will be negative, and sine positive.

$$\cos \frac{\theta}{2} = -\sqrt{\frac{1 + \cos \theta}{2}} = -\sqrt{\frac{1 + \frac{2}{3}}{2}} \left(\frac{3}{3}\right) = -\sqrt{\frac{5}{6}}$$

$$\sin \frac{\theta}{2} = +\sqrt{\frac{1 - \cos \theta}{2}} = +\sqrt{\frac{1 - \frac{2}{3}}{2}} \left(\frac{3}{3}\right) = +\sqrt{\frac{1}{6}}$$

Notice we didn't need $\sin \theta$; the half-angle formulas only use cosine.

Also there was **no** " $\cos \frac{2}{3}$ "! **2/3 is not an angle!** (At least not in this problem.)

Example 3.29: Say instead θ satisfies $-\pi \leq \theta \leq 0$ and $\cos \theta = \frac{2}{3}$.
Now what are $\cos \frac{\theta}{2}$ and $\sin \frac{\theta}{2}$?

The only things that change is the quadrant and the signs.

$$-\pi \leq \theta \leq 0 \quad \Rightarrow \quad -\frac{\pi}{2} \leq \frac{\theta}{2} \leq 0$$

Now $\theta/2$ is in quadrant IV, so

$$\cos \frac{\theta}{2} = +\sqrt{\frac{5}{6}}$$

$$\sin \frac{\theta}{2} = -\sqrt{\frac{1}{6}}$$

There are also double and half angle formulas for tangent.

$$\tan(x + x) = \frac{\tan(x) + \tan(x)}{1 - \tan(x)\tan(x)}$$

Gives,

$$\boxed{\tan(2x) = \frac{2\tan(x)}{1-\tan^2(x)}}$$

Using the half angle formulas for sine and cosine we have,

$$\tan\left(\frac{u}{2}\right) = \frac{\sin \frac{u}{2}}{\cos \frac{u}{2}} = \frac{\pm\sqrt{\frac{1-\cos(u)}{2}}}{\pm\sqrt{\frac{1+\cos(u)}{2}}} = \pm\sqrt{\frac{1-\cos(u)}{1+\cos(u)}}$$

Multiplying by the conjugate of the bottom gives

$$\tan\left(\frac{u}{2}\right) = \pm \sqrt{\frac{1 - \cos(u)}{1 + \cos(u)}} \left(\frac{1 - \cos(u)}{1 - \cos(u)} \right) = \pm \sqrt{\frac{(1 - \cos(u))^2}{1 - \cos^2(u)}} = \pm \left| \frac{1 - \cos(u)}{\sin(u)} \right|$$

Miraculously, the absolute values and the \pm cancel with each other.

You get a similar formula if you multiply by the conjugate of the top.

$$\boxed{\tan\left(\frac{u}{2}\right) = \frac{1 - \cos(u)}{\sin(u)} = \frac{\sin(u)}{1 + \cos(u)}}$$

Example 3.30: Use the half angle formula to find the exact value of $\tan \frac{\pi}{8}$.

Solution:

$$\begin{aligned} \tan \frac{\pi}{8} &= \tan\left(\frac{1}{2} \cdot \frac{\pi}{4}\right) = \frac{1 - \cos \frac{\pi}{4}}{\sin \frac{\pi}{4}} = \frac{1 - \frac{\sqrt{2}}{2}}{\frac{\sqrt{2}}{2}} \\ &= \left(1 - \frac{\sqrt{2}}{2}\right) \frac{2}{\sqrt{2}} = \frac{2}{\sqrt{2}} - 1 = \sqrt{2} - 1 \end{aligned}$$

Homework 3.2.2, 3.2.3, 3.2.4

1. Use a half-angle formula to find the exact value of the expression.

(a) $\cos(15^\circ)$

(b) $\sin\left(\frac{3\pi}{8}\right)$

(c) $\tan(75^\circ)$

2. Use a double angle formula to simplify the expression.

(a) $2 \sin(3\theta) \cos(3\theta)$

(b) $1 - 2 \sin^2(5x)$

(c) $\frac{2 \tan(7t)}{1 - \tan^2(7t)}$

3. Prove the identities.

(a)

$$\sin(8x) = 2 \sin(4x) \cos(4x)$$

(b)

$$\frac{1 + \sin(2x)}{\sin(2x)} = 1 + \frac{1}{2} \csc(x) \sec(x)$$

(c)

$$\frac{\sin(4x)}{\sin(x)} = 4 \cos(x) \cos(2x)$$

4. Simplify the expressions.

(a) $\cos\left(2 \cos^{-1}\left(\frac{3}{5}\right)\right)$

(b) $\tan\left(2 \sin^{-1}\left(\frac{3}{5}\right)\right)$

5. Find $\sin(x/2)$ and $\cos(x/2)$ from the given information.

(a) $\cos(x) = \frac{3}{5}$, $0^\circ < x < 90^\circ$

(b) $\sin(x) = -\frac{5}{13}$, $180^\circ < x < 270^\circ$

(c) $\csc(x) = 3$, $90^\circ < x < 180^\circ$

6. Write the sum as a product.

(a) $\sin(5x) + \sin(3x)$

(b) $\cos(4x) - \cos(6x)$

(c) $\sin(x) - \sin(4x)$

7. Write the product as a sum.

(a) $\sin(2x) \cos(3x)$

(b) $\cos(5x) \cos(3x)$

(c) $8 \sin(x) \sin(5x)$

8. Solve the equations.

(a)

$$\cos(2x) = \sin(x)$$

(b)

$$\tan\left(\frac{x}{2}\right) = \sin(x)$$

Further practice:

Page 557 (sec 7.3) #1-8, 15-72

Page 567 (sec 7.4) #45-48

Page 580 (sec 7.5) #67-70

Solutions

1. (a) $\frac{\sqrt{2+\sqrt{3}}}{2}$, (b) $\frac{\sqrt{2+\sqrt{2}}}{2}$

2. (a) $\sin(6\theta)$, (b) $\cos(10x)$ (c) $\tan(14t)$

3. (a)

$$\begin{aligned}\text{LHS} &= \sin(8x) \\ &= \sin(2(4x)) \\ &= 2\sin(4x)\cos(4x) = \text{RHS}\end{aligned}$$

(b)

$$\begin{aligned}\text{LHS} &= \frac{1+\sin(2x)}{\sin(2x)} \\ &= \frac{1}{\sin(2x)} + \frac{\sin(2x)}{\sin(2x)} \\ &= \frac{1}{2\sin(x)\cos(x)} + 1 \\ &= \frac{1}{2} \frac{1}{\sin(x)\cos(x)} + 1 \\ &= \frac{1}{2} \csc(x)\sec(x) + 1 = \text{RHS}\end{aligned}$$

(c)

$$\begin{aligned}\text{LHS} &= \frac{\sin(4x)}{\sin(x)} \\ &= \frac{\sin(2(2x))}{\sin(x)} \\ &= \frac{2\sin(2x)\cos(2x)}{\sin(x)} \\ &= \frac{2(2\sin(x)\cos(x))\cos(2x)}{\sin(x)} \\ &= 4\cos(x)\cos(2x) = \text{RHS}\end{aligned}$$

4. (a) $-\frac{7}{25}$, (b) $\frac{24}{7}$

5. (a) $\sin\left(\frac{x}{2}\right) = \frac{1}{\sqrt{5}}$, $\cos\left(\frac{x}{2}\right) = \frac{2}{\sqrt{5}}$

(b) $\sin\left(\frac{x}{2}\right) = \frac{5}{\sqrt{26}}$, $\cos\left(\frac{x}{2}\right) = \frac{-1}{\sqrt{26}}$

(c) $\sin\left(\frac{x}{2}\right) = \sqrt{\frac{3+2\sqrt{2}}{6}}$,

$$\cos\left(\frac{x}{2}\right) = \sqrt{\frac{3-2\sqrt{2}}{6}}$$

6. (a) $2\sin(4x)\cos(x)$

(b) $-2\sin(5x)\sin(-x) = 2\sin(5x)\sin(x)$

(c) $2\cos\left(\frac{5x}{2}\right)\sin\left(\frac{-3x}{2}\right) = -2\cos\left(\frac{5x}{2}\right)\sin\left(\frac{3x}{2}\right)$

7. (a) $\frac{1}{2}[\sin(-x) + \sin(5x)]$

(b) $\frac{1}{2}[\cos(2x) + \cos(8x)]$

(c) $4[\cos(-4x) - \cos(6x)]$

8. (a) The equation is the same as :
 $2\sin^2(x) + \sin(x) - 1 = 0$,

The solution is: $x = \frac{\pi}{6} + 2\pi n$, $x = \frac{5\pi}{6} + 2\pi n$, $x = \frac{3\pi}{2} + 2\pi n$ where n is any integer.

(b) The equation is the same as:

$$\frac{1 - \cos(x)}{\sin(x)} = \sin(x)$$

which simplifies to

$$\cos(x)(\cos(x) - 1) = 0$$

The solution is: $x = \frac{\pi}{2} + \pi n$, $x = 2\pi n$ where n is any integer.

3.3 Complex Numbers

Complex numbers are a surprisingly useful mathematical idea that turns up in many applied disciplines. A number of the important concepts in complex numbers are similar to those that come up when dealing with vectors (a subject we will study in the next chapter), and involve a lot of trigonometry.

You'll recall that complex numbers have the form: $a + bi$ where a and b are real numbers, and i is the so called "imaginary number", $\sqrt{-1}$.

Complex numbers can be added, subtracted, multiplied and divided just like regular numbers. One just has to remember that $i^2 = -1$.

Example 3.31: Let $z = 3 + 4i$ and $w = 1 + 7i$.
Find $z + w$, $z - w$, zw , and $\frac{z}{w}$.

Solution:

$$z + w = 3 + 4i + 1 + 7i = 4 + 11i$$

$$z - w = 3 + 4i - 1 - 7i = 2 - 3i$$

$$zw = (3 + 4i) \cdot (1 + 7i) = 3 + 21i + 4i + 28i^2$$

$$= 3 + 21i + 4i - 28 = -25 + 25i$$

$$\frac{z}{w} = \frac{3+4i}{1+7i} \cdot \left(\frac{1-7i}{1-7i}\right) = \frac{3-21i+4i-28i^2}{1-49i^2}$$

$$= \frac{31-17i}{1+49} = \frac{31}{50} - \frac{17}{50}i$$

A very useful way to think about complex numbers is as points in the plane.

For a complex number $z = a + bi$, the real part of the complex number (a) provides the x -coordinate while the imaginary part (b) provides the y -coordinate.

The complex number $z = 3 + 2i$ corresponds to the point in the plane $(3, 2)$.

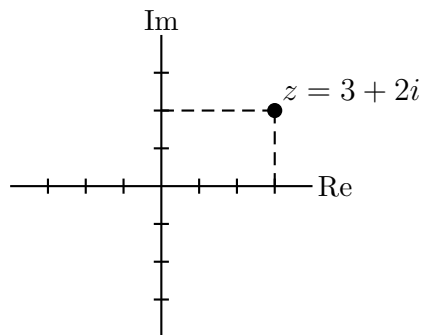

3.3.1 Trigonometric Form

A complex number written as $z = a + bi$ is said to be in **standard form**. However, a point in the plane can also be described with a distance from the origin and an angle with the

positive x -axis. These two quantities can be combined to make the “trigonometric form” of a complex number.

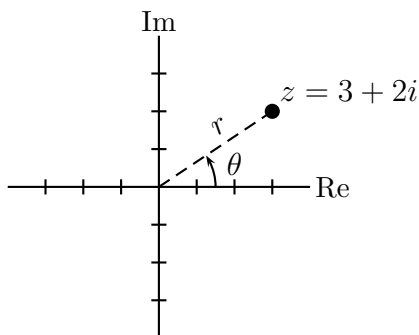

The distance from the origin, r , is called the **complex modulus**, denoted $|z|$.

$$r = |z| = \sqrt{3^2 + 2^2} = \sqrt{13}$$

The angle from the positive x -axis, θ , is called the **argument**, denoted $\text{Arg}(z)$.

$$\theta = \text{Arg}(z) = \sin^{-1}\left(\frac{2}{\sqrt{13}}\right) \approx 33.7^\circ$$

Definition: The **complex modulus** of a complex number $z = a + bi$ is:

$$|z| = \sqrt{a^2 + b^2}$$

The **argument** of z is the angle so that:

$$\cos(\text{Arg}(z)) = \frac{a}{|z|} \quad \text{and} \quad \sin(\text{Arg}(z)) = \frac{b}{|z|}$$

Definition: The **trigonometric form** of a complex number z with complex modulus r and argument θ is:

$$z = r \cos(\theta) + r \sin(\theta) i$$

Example 3.32: Approximate the trigonometric form of $z = 3 + 2i$.

Solution: We’ve already seen that $|z| = \sqrt{13}$ and $\text{Arg}(z) \approx 33.7^\circ$, thus

$$z \approx \sqrt{13} \cos(33.7^\circ) + \sqrt{13} \sin(33.7^\circ) i$$

Example 3.33: Find the trigonometric form of $z = -1 + \sqrt{3} i$.

Solution: $|z| = \sqrt{(-1)^2 + (\sqrt{3})^2} = 2$.

$$\cos(\text{Arg}(z)) = \frac{-1}{2} \quad \text{and} \quad \sin(\text{Arg}(z)) = \frac{\sqrt{3}}{2}$$

The reference angle is $\pi/3$, and the quadrant is II, so $\text{Arg}(z) = \frac{2\pi}{3}$. Thus,

$$z = 2 \cos\left(\frac{2\pi}{3}\right) + 2 \sin\left(\frac{2\pi}{3}\right) i$$

Notice that you can check your answer if you evaluate the cosine and sine of $2\pi/3$,

$$2 \cos\left(\frac{2\pi}{3}\right) + 2 \sin\left(\frac{2\pi}{3}\right) i = 2\left(-\frac{1}{2}\right) + 2\left(\frac{\sqrt{3}}{2}\right) i = -1 + \sqrt{3} i = z \quad \checkmark$$

Example 3.34: Find the trigonometric form of $z = 1 - i$.

$$|z| = \sqrt{1^2 + (-1)^2} = \sqrt{2}.$$

$$\cos(\operatorname{Arg}(z)) = \frac{1}{\sqrt{2}} \quad \text{and} \quad \sin(\operatorname{Arg}(z)) = \frac{-1}{\sqrt{2}}$$

The reference angle is $\pi/4$, and the quadrant is IV, so $\operatorname{Arg}(z) = \frac{7\pi}{4}$. Thus,

$$z = \sqrt{2} \cos\left(\frac{7\pi}{4}\right) + \sqrt{2} \sin\left(\frac{7\pi}{4}\right) i$$

Example 3.35: Find the trigonometric form of $z = -3$.

$$|z| = \sqrt{(-3)^2 + (0)^2} = 3.$$

$$\cos(\operatorname{Arg}(z)) = \frac{-3}{3} \quad \text{and} \quad \sin(\operatorname{Arg}(z)) = \frac{0}{3}$$

Clearly $\operatorname{Arg}(z) = \pi$. Thus,

$$z = 3 \cos(\pi) + 3 \sin(\pi) i$$

Example 3.36: Approximate the trigonometric form of $z = -12 - 5i$.

$$|z| = \sqrt{(-12)^2 + (-5)^2} = 13.$$

$$\cos(\operatorname{Arg}(z)) = \frac{-12}{13} \quad \text{and} \quad \sin(\operatorname{Arg}(z)) = \frac{-5}{13}$$

The reference angle is $\cos^{-1}(+12/13) \approx 22.6^\circ$, and the quadrant is III, so $\operatorname{Arg}(z) \approx 202.6^\circ$. Thus,

$$z \approx 13 \cos(202.6^\circ) + 13 \sin(202.6^\circ) i$$

The trigonometric form is so useful that there are two types of notation signifying it.

$$\boxed{\text{Euler's Formula: } e^{i\theta} = \cos \theta + \sin \theta i} \quad \text{and} \quad \boxed{\text{cis}(\theta) = \cos \theta + \sin \theta i}$$

Thus from example 3.33,

$$-1 + \sqrt{3}i = 2e^{\frac{2\pi}{3}i}$$

and from example 3.32,

$$3 + 2i \approx \sqrt{13} \text{cis}(33.7^\circ)$$

3.3.2 Product, Quotient, and Power

The standard form is best when adding or subtracting complex numbers, but the trigonometric form is a little better when multiplying them, and vastly better when raising them to a power. When multiplying two complex numbers you multiply the moduli, but **add the arguments**.

Say you have two complex numbers in their trigonometric forms:

$$z_1 = r_1 \cos \theta_1 + r_1 \sin \theta_1 i \quad \text{and} \quad z_2 = r_2 \cos \theta_2 + r_2 \sin \theta_2 i$$

Then, using the sum and difference formulas,

$$\begin{aligned} z_1 \cdot z_2 &= (r_1 \cos \theta_1 + r_1 \sin \theta_1 i) \cdot (r_2 \cos \theta_2 + r_2 \sin \theta_2 i) \\ &= r_1 r_2 (\cos \theta_1 \cos \theta_2 - \sin \theta_1 \sin \theta_2) + r_1 r_2 (\sin \theta_1 \cos \theta_2 + \sin \theta_1 \cos \theta_2) i \\ &= r_1 r_2 (\cos(\theta_1 + \theta_2)) + r_1 r_2 (\sin(\theta_1 + \theta_2)) i \end{aligned}$$

Or in other words,

$$\boxed{r_1 \text{cis}(\theta_1) \cdot r_2 \text{cis}(\theta_2) = r_1 r_2 \text{cis}(\theta_1 + \theta_2)}$$

It is as if the arguments, θ_1 and θ_2 , behave like the exponents in the formula:

$$x^a \cdot x^b = x^{a+b}$$

This is one reason why Euler chose his notation; so that $e^{i\theta_1} \cdot e^{i\theta_2} = e^{i(\theta_1 + \theta_2)}$

The other complex number formulas we will study show the same similarity to exponents.

Example 3.37: Find the trig form of $(-1 + \sqrt{3}i) \cdot (\sqrt{3} + i)$.

Solution: First we need the trig form of $z = \sqrt{3} + i$. $|z| = \sqrt{(\sqrt{3})^2 + 1^2} = 2$.

Since $\cos \theta = \frac{\sqrt{3}}{2}$ and $\sin \theta = \frac{1}{2}$ the argument is $\pi/6$. Thus $z = 2 \text{cis}(\frac{\pi}{6})$

From example 3.33 we have the trig form of $-1 + \sqrt{3}i$ is $2 \text{cis}(\frac{2\pi}{3})$. Thus,

$$(-1 + \sqrt{3}i) \cdot (\sqrt{3} + i) = 2 \text{cis}\left(\frac{\pi}{6}\right) \cdot 2 \text{cis}\left(\frac{2\pi}{3}\right) = 4 \text{cis}\left(\frac{\pi}{6} + \frac{2\pi}{3}\right) = 4 \text{cis}\left(\frac{5\pi}{6}\right)$$

We can easily check this result by “foiling out” the product.

$$(-1 + \sqrt{3} i) \cdot (\sqrt{3} + i) = -\sqrt{3} - i + (\sqrt{3})^2 i + \sqrt{3} i^2 = -2\sqrt{3} + 2i$$

while

$$4 \operatorname{cis} \left(\frac{5\pi}{6} \right) = 4 \cos \left(\frac{5\pi}{6} \right) + 4 \sin \left(\frac{5\pi}{6} \right) i = 4 \left(-\frac{\sqrt{3}}{2} \right) + 4 \left(\frac{1}{2} \right) i = -2\sqrt{3} + 2i$$

Quotients of complex numbers behave similarly. Since

$$\frac{x^a}{x^b} = x^{a-b} \quad \text{we have: } \boxed{\frac{r_1 \operatorname{cis}(\theta_1)}{r_2 \operatorname{cis}(\theta_2)} = \frac{r_1}{r_2} \operatorname{cis}(\theta_1 - \theta_2)}$$

Example 3.38: Find the trig form of $\frac{-1+\sqrt{3}i}{\sqrt{3}+i}$. Check by doing the division.

We change to trigonometric form and apply the formula:

$$\frac{-1 + \sqrt{3} i}{\sqrt{3} + i} = \frac{2 \operatorname{cis} \left(\frac{2\pi}{3} \right)}{2 \operatorname{cis} \left(\frac{\pi}{6} \right)} = 1 \cdot \operatorname{cis} \left(\frac{2\pi}{3} - \frac{\pi}{6} \right) = \operatorname{cis} \left(\frac{\pi}{2} \right) = i$$

Checking by multiplying by the conjugate of the denominator:

$$\frac{-1 + \sqrt{3} i}{\sqrt{3} + i} \cdot \left(\frac{\sqrt{3} - i}{\sqrt{3} - i} \right) = \frac{-\sqrt{3} + i + 3i - \sqrt{3}i^2}{3 - i^2} = \frac{4i}{4} = i \quad \checkmark$$

But where the trig form really begins to pay off is with powers. Once again following the example of exponents, since

$$(x^a)^n = x^{na} \quad \text{we have } \mathbf{D'Moivre's Theorem:} \quad \boxed{(r \operatorname{cis}(\theta))^n = r^n \operatorname{cis}(n\theta)}$$

Example 3.39: Use example 3.33 and D'Moivre's Theorem to simplify:
 $(-1 + \sqrt{3} i)^3$

Solution: From example 3.33 we know the trig form of $-1 + \sqrt{3} i$ is $2 \operatorname{cis} \left(\frac{2\pi}{3} \right)$. Thus,

$$\begin{aligned} (-1 + \sqrt{3} i)^3 &= \left(2 \operatorname{cis} \left(\frac{2\pi}{3} \right) \right)^3 = 2^3 \operatorname{cis} \left(3 \frac{2\pi}{3} \right) = 8 \operatorname{cis}(2\pi) \\ &= 8(\cos(2\pi) + \sin(2\pi)i) = 8(1 + 0i) = 8 \end{aligned}$$

Is it really just 8?! We can check without too much difficulty.

$$(-1 + \sqrt{3}i)^2 = (-1 + \sqrt{3}i) \cdot (-1 + \sqrt{3}i) = 1 - \sqrt{3}i - \sqrt{3}i - 3 = -2 - 2\sqrt{3}i$$

So,

$$\begin{aligned} (-1 + \sqrt{3}i)^3 &= (-1 + \sqrt{3}i)^2 \cdot (-1 + \sqrt{3}i) \\ &= (-2 - 2\sqrt{3}i) \cdot (-1 + \sqrt{3}i) = 2 - 2\sqrt{3}i + 2\sqrt{3}i + 6 = 8 \end{aligned}$$

Well how about that... Math works.

Example 3.40: Use example 3.34 and D'Moivre's Theorem to simplify:

$$(1 - i)^4$$

$$(1 - i)^4 = \left(\sqrt{2} \operatorname{cis} \left(\frac{7\pi}{4} \right) \right)^4 = (\sqrt{2})^4 \operatorname{cis} \left(4 \cdot \frac{7\pi}{4} \right) = 4 \operatorname{cis}(7\pi) = -4$$

3.3.3 Roots

Using the trig form and D'Moivre's Theorem is the best way to take a complex number to some whole number power. However it is the **only way** to take a complex number to a fractional power—that is to say, **a root**.

Everyone remembers how to solve the following equation:

$$x^2 = 9 \quad \Rightarrow \quad x = \pm\sqrt{9} \quad \Rightarrow \quad x = +3 \quad \text{or} \quad x = -3$$

But what if you want to solve an equation like:

$$z^2 = i \quad \Rightarrow \quad z = \pm\sqrt{i} \quad \Rightarrow \quad ???$$

What does \sqrt{i} even mean? It should be a number which, when squared, gives i . But how to find such a number?

Try D'Moivre's Theorem even though the power is a fraction, $\frac{1}{2}$. Of course first you have to write i in the trig form: $i = 1 \operatorname{cis}(\pi/2)$. So,

$$\left(1 \operatorname{cis} \left(\frac{\pi}{2} \right) \right)^{\frac{1}{2}} = 1^{\frac{1}{2}} \operatorname{cis} \left(\frac{1}{2} \cdot \frac{\pi}{2} \right) = \operatorname{cis} \left(\frac{\pi}{4} \right) = \cos \left(\frac{\pi}{4} \right) + \sin \left(\frac{\pi}{4} \right) i = \frac{\sqrt{2}}{2} + \frac{\sqrt{2}}{2} i$$

And you can check easily enough that

$$\left(\frac{\sqrt{2}}{2} + \frac{\sqrt{2}}{2}i\right)^2 = \frac{1}{2} + 2\frac{1}{2}i - \frac{1}{2} = i \checkmark$$

So apparently $\sqrt{i} = \frac{\sqrt{2}}{2} + \frac{\sqrt{2}}{2}i$

There is a subtlety here, though. $\frac{\pi}{2}$ and $\frac{\pi}{2} + 2\pi = \frac{5\pi}{2}$ are co-terminal angles. They have the same sine and cosine, so:

$$i = \text{cis}\left(\frac{\pi}{2}\right) = \text{cis}\left(\frac{5\pi}{2}\right)$$

But look what happens if you “square root” the second trig form:

$$\left(1 \text{cis}\left(\frac{5\pi}{2}\right)\right)^{\frac{1}{2}} = 1^{\frac{1}{2}} \text{cis}\left(\frac{1}{2} \cdot \frac{5\pi}{2}\right) = \text{cis}\left(\frac{5\pi}{4}\right) = \cos\left(\frac{5\pi}{4}\right) + \sin\left(\frac{5\pi}{4}\right)i = -\frac{\sqrt{2}}{2} - \frac{\sqrt{2}}{2}i$$

It’s different! Oh, but wait—it’s just $-\sqrt{i}$.

So there are two solutions to $z^2 = i$, and they are: $z = \pm\left(\frac{\sqrt{2}}{2} + \frac{\sqrt{2}}{2}i\right)$

Visually,

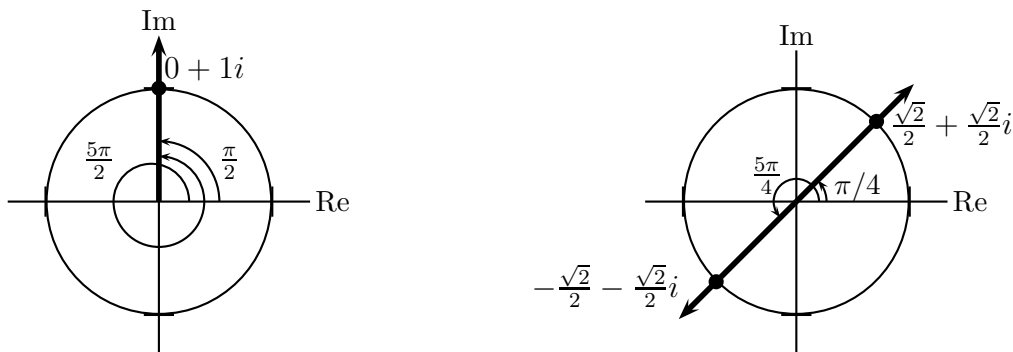

In general $z^n = w$ has n solutions, each found by looking at angles co-terminal to the argument of w , and spread evenly around the circle of radius $\sqrt[n]{|w|}$.

$z^n = r \text{cis}(\theta)$ has solutions:

$$z = \sqrt[n]{r} \text{cis}\left(\frac{\theta + 2\pi k}{n}\right) \text{ for } k = 0, 1 \dots n - 1.$$

Example 3.41: Find the three solutions to: $z^3 = 8$

Solution: $8 = 8 \operatorname{cis}(0)$, so

$$z_1 = (8 \operatorname{cis}(0))^{\frac{1}{3}} = 8^{\frac{1}{3}} \operatorname{cis}\left(\frac{0}{3}\right) = 2 \operatorname{cis}(0) = 2$$

That one we all could have gotten without complex numbers, but the others...

$8 = 8 \operatorname{cis}(2\pi)$, also

$$\begin{aligned} z_2 &= (8 \operatorname{cis}(2\pi))^{\frac{1}{3}} = 8^{\frac{1}{3}} \operatorname{cis}\left(\frac{2\pi}{3}\right) = 2 \left(\cos\left(\frac{2\pi}{3}\right) + \sin\left(\frac{2\pi}{3}\right) i \right) \\ &= 2 \left(-\frac{1}{2} + \frac{\sqrt{3}}{2} i \right) = -1 + \sqrt{3} i \end{aligned}$$

This is the solution we found in example 3.39.

For the third solution $8 = 8 \operatorname{cis}(4\pi)$

$$\begin{aligned} z_3 &= (8 \operatorname{cis}(4\pi))^{\frac{1}{3}} = 8^{\frac{1}{3}} \operatorname{cis}\left(\frac{4\pi}{3}\right) = 2 \left(\cos\left(\frac{4\pi}{3}\right) + \sin\left(\frac{4\pi}{3}\right) i \right) \\ &= 2 \left(-\frac{1}{2} - \frac{\sqrt{3}}{2} i \right) = -1 - \sqrt{3} i \end{aligned}$$

What would have happened if I'd looked for a fourth solution? $8 = 8 \operatorname{cis}(6\pi)$

$$z_4 = (8 \operatorname{cis}(6\pi))^{\frac{1}{3}} = 8^{\frac{1}{3}} \operatorname{cis}\left(\frac{6\pi}{3}\right) = 2 \operatorname{cis}(2\pi) = 2$$

So we just start over again at z_1 .

Visually,

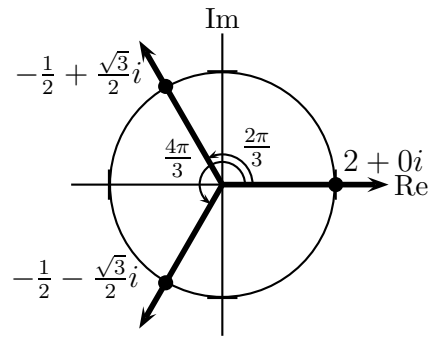
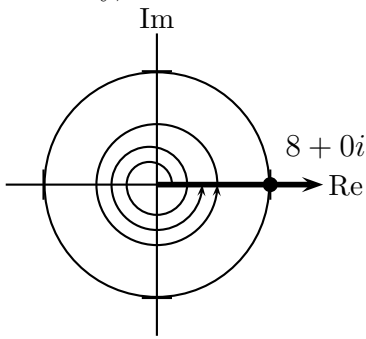

Example 3.42: Find all four solutions to: $z^4 = 1 + i$
(Leave them in the trig form.)

First note that $1 + i = \sqrt{2} \operatorname{cis} \left(\frac{\pi}{4} \right)$. Then,

$$z_1 = \left(\sqrt{2} \operatorname{cis} \left(\frac{\pi}{4} \right) \right)^{\frac{1}{4}} = (\sqrt{2})^{\frac{1}{4}} \operatorname{cis} \left(\frac{1}{4} \cdot \frac{\pi}{4} \right) = 2^{\frac{1}{8}} \operatorname{cis} \left(\frac{\pi}{16} \right)$$

Similarly since $1 + i$ is also $\sqrt{2} \operatorname{cis} \left(\frac{9\pi}{4} \right)$,

$$z_2 = \left(\sqrt{2} \operatorname{cis} \left(\frac{9\pi}{4} \right) \right)^{\frac{1}{4}} = (\sqrt{2})^{\frac{1}{4}} \operatorname{cis} \left(\frac{1}{4} \cdot \frac{9\pi}{4} \right) = 2^{\frac{1}{8}} \operatorname{cis} \left(\frac{9\pi}{16} \right)$$

and

$$z_3 = 2^{\frac{1}{8}} \operatorname{cis} \left(\frac{17\pi}{16} \right)$$

$$z_4 = 2^{\frac{1}{8}} \operatorname{cis} \left(\frac{25\pi}{16} \right)$$

Homework 3.3

- Write the following complex numbers exactly in the trigonometric form.
 - $-1 + i$
 - $3 - 3\sqrt{3}i$
 - $-5 - 5i$
 - -8
- Use your calculator to approximate the trigonometric form of the following complex numbers.
 - $5 + 12i$
 - $3 - 2i$
 - $-3 - 4i$
 - $-8 + 7i$
- Convert the following complex numbers into the standard form. (Use your calculator if necessary.)
 - $4e^{\frac{i\pi}{3}}$
 - $2e^{\frac{i7\pi}{6}}$
 - $5\text{cis}(123^\circ)$
 - $3\text{cis}(331^\circ)$
- Let $z = 4\text{cis}(97^\circ)$ and $w = 2\text{cis}(31^\circ)$. Find the trigonometric form of the results of the following operations.
 - zw
 - $\frac{z}{w}$
 - z^3
 - $\frac{1}{w^4}$
- Find the standard form of **all** solutions to the following equations.
 - $z^2 = -i$
 - $z^3 = -8$
 - $z^4 = 81$

Further practice: Page 589 (sec 7.6) #1-14, 23-90

Solutions

- (a) $\sqrt{2}\text{cis}(135^\circ)$, (b) $6\text{cis}(300^\circ)$, (c) $5\sqrt{2}\text{cis}(225^\circ)$, (d) $8\text{cis}(180^\circ)$
- (a) $13\text{cis}(67.4^\circ)$, (b) $\sqrt{13}\text{cis}(-33.7^\circ)$, (c) $5\text{cis}(233.1^\circ)$, (d) $\sqrt{113}\text{cis}(136.9^\circ)$
- (a) $2 + 2i\sqrt{3}$, (b) $-\sqrt{3} - i$, (c) $-2.723 + 4.193i$, (d) $2.624 - 1.454i$
- (a) $8\text{cis}(128^\circ)$, (b) $2\text{cis}(66^\circ)$, (c) $64\text{cis}(291^\circ)$, (d) $\frac{1}{16}\text{cis}(-124^\circ)$,
- (a) $-\frac{\sqrt{2}}{2} + \frac{\sqrt{2}}{2}i$, $\frac{\sqrt{2}}{2} - \frac{\sqrt{2}}{2}i$ (b) $1 + \sqrt{3}i$, -2 , $1 - \sqrt{3}i$
(c) $3\text{cis}(0^\circ)$, $3\text{cis}(90^\circ)$, $3\text{cis}(180^\circ)$, $3\text{cis}(270^\circ)$ -OR- ± 3 , $\pm 3i$

Chapter 4

Trigonometric Geometry

We now turn our attention to using trigonometry to solve geometric problems. Many of these are applied problems which mostly involve finding the angles and lengths of a triangle. Usually the triangle is **not a right triangle**.

We have two main tools for dealing with general triangles: The Law of Sines and the Law of Cosines.

4.1 Law of Sines

Consider a general triangle with interior angles A, B, C and sides opposite of lengths a, b, c , respectively. There are some relationships between the sides and the angles.

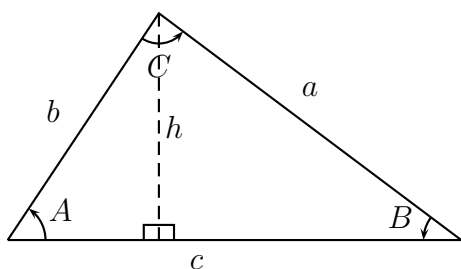

$$\sin A = \frac{h}{b} \quad \sin B = \frac{h}{a}$$

$$\Rightarrow b \sin A = h = a \sin B$$

$$\Rightarrow \frac{\sin A}{a} = \frac{\sin B}{b}$$

Similar arguments can be given to show this relationship works for C and c as well.

Law of Sines:

$$\boxed{\frac{\sin A}{a} = \frac{\sin B}{b} = \frac{\sin C}{c}}$$

Example 4.1: Find the angle A and the sides a and b for the triangle below.

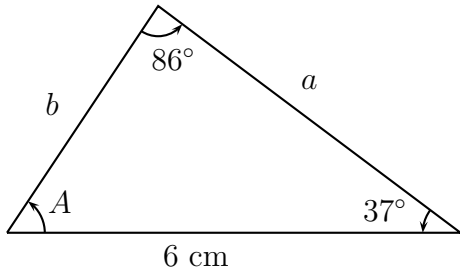

$$A = 180^\circ - 37^\circ - 86^\circ = 57^\circ$$

$$\frac{\sin 37^\circ}{b} = \frac{\sin 86^\circ}{6}$$

$$\Rightarrow b = 6 \frac{\sin 37^\circ}{\sin 86^\circ}$$

$$b \approx 3.62 \text{ cm}$$

$$\frac{\sin 57^\circ}{a} = \frac{\sin 86^\circ}{6}$$

$$\Rightarrow a = 6 \frac{\sin 57^\circ}{\sin 86^\circ}$$

$$a \approx 5.04 \text{ cm}$$

Example 4.2: A tower sits at the top of a hill which has a 58° slope. A guy wire secures the top of the tower to an anchor 100 meters down the hill. The wire has an angle of elevation of 70° . How long should the wire be?

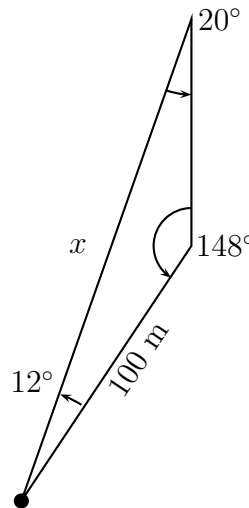
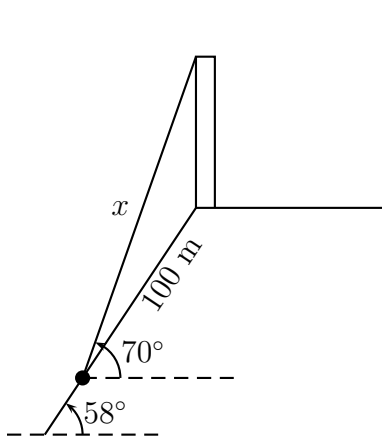

$$70^\circ - 58^\circ = 12^\circ$$

$$90^\circ - 70^\circ = 20^\circ$$

$$180^\circ - 20^\circ - 12^\circ = 148^\circ$$

$$\frac{\sin 148^\circ}{x} = \frac{\sin 20^\circ}{100}$$

$$\Rightarrow x = 100 \frac{\sin 148^\circ}{\sin 20^\circ}$$

$$x \approx 155 \text{ m}$$

Example 4.3: A helicopter is flying over a section of straight road. In one direction along the road, at an angle of declination of 28° , is a Wal-Mart. In the other direction, at an angle of declination of 36° is a Home Depot. The pilot knows from having driven the road that the Wal-Mart is 5 miles from the Home Depot.

How high is the helicopter flying? (Be sure to draw a picture first!)

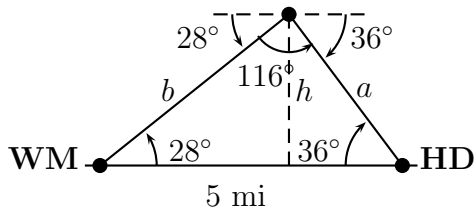

$$\frac{\sin(28^\circ)}{a} = \frac{\sin(116^\circ)}{5}$$

$$\Rightarrow a = \frac{5 \sin(28^\circ)}{\sin(116^\circ)} \approx 2.61 \text{ mi}$$

$$\sin(36^\circ) = \frac{h}{a}$$

$$\Rightarrow h = (2.61) \sin(36^\circ) \approx 1.54 \text{ mi}$$

4.1.1 Ambiguous Case

The cases we've dealt with so far involve triangles where two angles and one side opposite one of the angles are known (SAA). The Law of Sines can be used to find the one triangle with those angles and that side. The Law of Sines can also be used to find triangles if two sides and an angle opposite one of the sides is known, but there is a complication. There may be two triangles, one, or no triangles at all that satisfy the information given.

Consider a triangle with an angle of 30° , a side opposite it of length a , and another side of length 10. There are four possibilities depending on the length of the side a .

1. $a < 5 \Rightarrow$ No possible triangle.

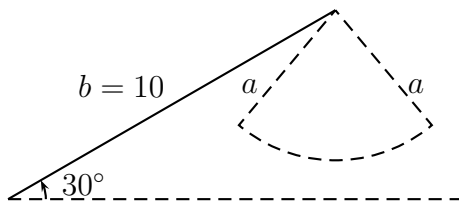

$$\frac{\sin 30^\circ}{a} = \frac{\sin B}{10}$$

$$\Rightarrow \sin B = \frac{10 \sin 30^\circ}{a} = \frac{5}{a} > 1$$

No possible angle B .

2. $a = 5 \Rightarrow$ One right triangle.

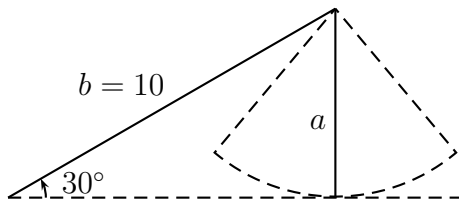

$$\Rightarrow \sin B = \frac{10 \sin 30^\circ}{a} = \frac{5}{a} = 1$$

Only possible angle $B = 90^\circ$.

3. $5 < a < 10 \Rightarrow$ Two possible triangles.

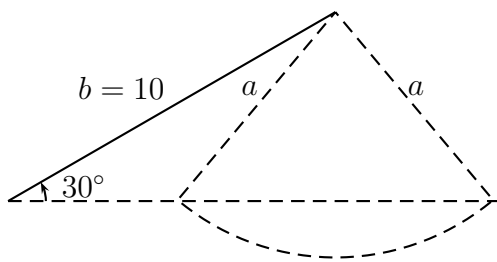

$$\Rightarrow \sin B = \frac{10 \sin 30^\circ}{a} = \frac{5}{a} < 1$$

Two possible angles: $B = \sin^{-1}\left(\frac{5}{a}\right)$
 or
 $B = 180^\circ - \sin^{-1}\left(\frac{5}{a}\right)$.

4. $10 < a \Rightarrow$ One possible triangle.

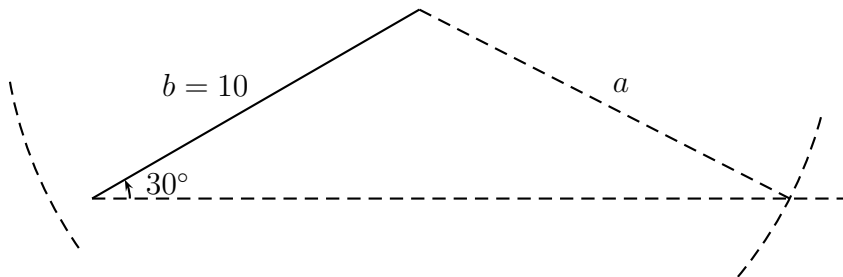

Example 4.4: Find all triangles with $a = 14$ cm, $b = 19$ cm, and $A = 42^\circ$.

Solution:

$$\frac{\sin 42^\circ}{14} = \frac{\sin B}{19}$$

$$\Rightarrow \sin B = \frac{19 \sin 42^\circ}{14} \approx 0.9081$$

$$\Rightarrow B \approx \sin^{-1}(0.9081) \approx 65.2^\circ$$

or

$$B \approx 180^\circ - 65.2^\circ = 114.8^\circ$$

Case 1: $B = 65.2^\circ$

$$\Rightarrow C \approx 180^\circ - 42^\circ - 65.2^\circ = 72.8^\circ$$

$$\frac{\sin 72.8^\circ}{c} = \frac{\sin 42^\circ}{14}$$

$$\Rightarrow c = \frac{14 \sin 72.8^\circ}{\sin 42^\circ} \approx 20.0 \text{ cm}$$

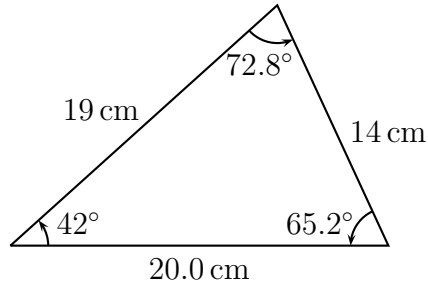

Case 2: $B = 114.8^\circ$

$$\Rightarrow C \approx 180^\circ - 42^\circ - 114.8^\circ = 23.2^\circ$$

$$\frac{\sin 23.2^\circ}{c} = \frac{\sin 42^\circ}{14}$$

$$\Rightarrow c = \frac{14 \sin 23.2^\circ}{\sin 42^\circ} \approx 8.2 \text{ cm}$$

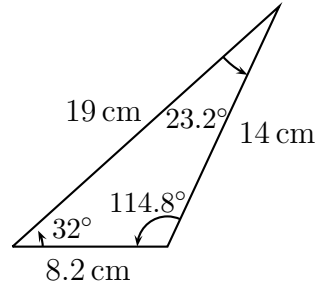

Example 4.5: Find all triangles with $a = 13 \text{ cm}$, $b = 10 \text{ cm}$, and $A = 32^\circ$.

$$\frac{\sin(32^\circ)}{13} = \frac{\sin(B)}{10} \Rightarrow \sin(B) = \frac{10 \sin(32^\circ)}{13} \approx .4076$$

$$\Rightarrow B \approx 24^\circ \text{ or } 156^\circ$$

Case 1: $B = 24^\circ$

$$\Rightarrow C \approx 180^\circ - 32^\circ - 24^\circ = 124^\circ$$

$$\frac{\sin 124^\circ}{c} = \frac{\sin 32^\circ}{13}$$

$$\Rightarrow c = \frac{13 \sin 124^\circ}{\sin 32^\circ} \approx 20.3 \text{ cm}$$

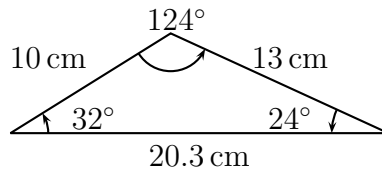

Case 2: $B = 156^\circ$

$$\Rightarrow C \approx 180^\circ - 32^\circ - 156^\circ = -8^\circ \text{ ???}$$

There is no second triangle

Example 4.6: Find all triangles with $a = 5$ cm, $b = 13$ cm, and $A = 21^\circ$. Sketch the corresponding triangle(s).

$$\frac{\sin(21^\circ)}{5} = \frac{\sin(B)}{13} \Rightarrow \sin(B) = \frac{13 \sin(21^\circ)}{5} \approx .9318$$

$$\Rightarrow B \approx 68.7^\circ \text{ or } 111.3^\circ$$

Case 1: $B = 68.7^\circ$

$$\Rightarrow C \approx 180^\circ - 21^\circ - 68.7^\circ = 90.3^\circ$$

$$\frac{\sin 90.3^\circ}{c} = \frac{\sin 21^\circ}{5}$$

$$\Rightarrow c = \frac{5 \sin 90.3^\circ}{\sin 21^\circ} \approx 14.0 \text{ cm}$$

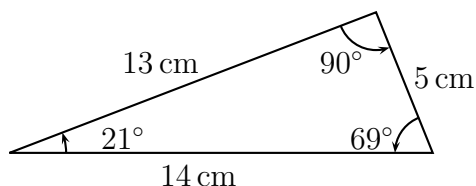

Case 2: $B = 111.3^\circ$

$$\Rightarrow C \approx 180^\circ - 21^\circ - 111.3^\circ = 47.7^\circ$$

$$\frac{\sin 47.7^\circ}{c} = \frac{\sin 21^\circ}{5}$$

$$\Rightarrow c = \frac{5 \sin 47.7^\circ}{\sin 21^\circ} \approx 10.3 \text{ cm}$$

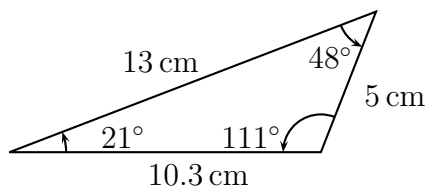

Homework 4.1

- Use the Law of Sines to find all possible triangles satisfying the given conditions.

(a) $a = 28$, $b = 15$, $A = 110^\circ$

(b) $a = 25$, $b = 30$, $A = 25^\circ$

(c) $a = 20$, $b = 45$, $A = 125^\circ$

(d) $a = 42$, $b = 45$, $A = 38^\circ$

- A tree on a hillside casts a shadow 215 ft down the hill. If the angle of inclination of the hillside is 22° , and the angle of elevation of the sun is 52° , find the height of the tree.

- A hiker is approaching a mountain. The top of the mountain is at an angle of el-

evation of 25° . After the hiker crosses 800 ft of level ground directly towards the mountain, the angle of elevation becomes 29° .

Find the height of the mountain.

- To find the distance across a river a surveyor chooses points A and B, which are 200 feet apart on one side of the river. She then chooses a reference point C on the opposite side of the river and finds that the angles $\angle BAC = 82^\circ$ and $\angle ABC = 52^\circ$.

Approximate the distance across the river.

Further practice: Page 510 (sec 6.4) #1-31

Solutions Note: Some answers are approximate.

1. (a) $B = 30.2^\circ, C = 39.8^\circ, c = 19.1$
(b) Two Triangles: $B = 30.5^\circ, C = 124.5^\circ, c = 48.8$ or $B = 149.5^\circ, C = 5.5^\circ, c = 5.7$
(c) No Triangle
(d) Two Triangles: $B = 41.3^\circ, C = 100.7^\circ, c = 67$ or $B = 138.7^\circ, C = 3.3^\circ, c = 3.9$
2. About 175 ft
3. About 2350 ft
4. About 217 ft

4.2 Law of Cosines

The Law of Sines allows us to solve triangles where a side and the angle opposite are known if you know one other side or angle. Thus we can solve SSA or SAA triangles. But what about triangles where two sides and the angle between them are known? (SAS) Or where all three sides are known, but no angles? (SSS) For these we need the Law of Cosines.

Consider first the triangle where the angle A and the sides b and c are known. We want to find the side a . We draw a line from the top vertex perpendicular to the base, forming two right triangles.

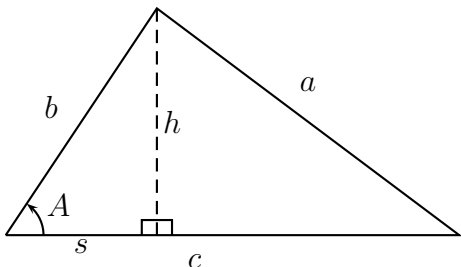

$$\sin A = \frac{h}{b} \quad \cos A = \frac{s}{b}$$

$$\Rightarrow h = b \sin A, \quad s = b \cos A$$

$$\begin{aligned} a^2 &= h^2 + (c - s)^2 \\ &= h^2 + c^2 - 2cs + s^2 \\ &= b^2 \sin^2 A + c^2 - 2bc \cos A + b^2 \cos^2 A \\ &= b^2 + c^2 - 2bc \cos A \end{aligned}$$

This is the Law of Cosines: $a^2 = b^2 + c^2 - 2bc \cos A$

If one knows the three sides and wants to find the angle, then solve for the angle A :

$$A = \cos^{-1} \left(\frac{b^2 + c^2 - a^2}{2bc} \right)$$

Example 4.7: Solve the triangle with sides 11 cm and 8 cm, and an angle between the sides of 24° .

Solution:

$$a^2 = 11^2 + 8^2 - 2 \cdot 11 \cdot 8 \cdot \cos 24^\circ \approx 24.22$$

$$a \approx \sqrt{24.22} \approx 4.92 \text{ cm}$$

$$B \approx \cos^{-1} \left(\frac{4.92^2 + 8^2 - 11^2}{2 \cdot 4.92 \cdot 8} \right) \approx 114.6^\circ$$

$$C \approx 180^\circ - 24^\circ - 114.6^\circ = 41.4^\circ$$

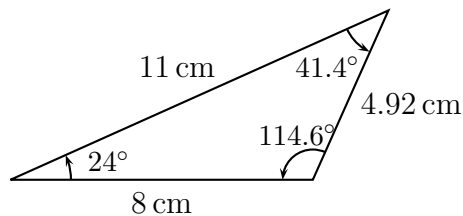

A common error on these problems is to use the Law of Sines to find the angle B . The problem here is that the Law of Sines produces **two** possible angles, only one of which is

correct. (There are no ambiguous cases for SAS or SSS triangles.) Say you tried to use the Law of Sines for example 4.7.

$$\frac{\sin 24^\circ}{4.92} = \frac{\sin B}{11} \Rightarrow \sin B = \frac{11 \sin 24^\circ}{4.92} \approx 0.9093$$

$$\Rightarrow B = \sin^{-1} 0.9093 \approx 65.4^\circ$$

OR

$$B \approx 180^\circ - 65.4^\circ = 114.6^\circ$$

Most students forget the second possibility—which in this case is the **only** correct one.

The moral of this story is that when you are looking for an angle, the Law of Sines can let you down. The Law of Cosines never will.

Example 4.8: Solve the triangle with sides 9 cm and 8 cm, and an angle between the sides of 54° .

$$a^2 = 9^2 + 8^2 - 2 \cdot 9 \cdot 8 \cdot \cos 54^\circ \approx 60.36$$

$$a \approx \sqrt{60.36} \approx 7.77 \text{ cm}$$

$$B \approx \cos^{-1} \left(\frac{7.77^2 + 8^2 - 9^2}{2 \cdot 7.77 \cdot 8} \right) \approx 69.6^\circ$$

$$C \approx 180^\circ - 54^\circ - 69.6^\circ = 56.4^\circ$$

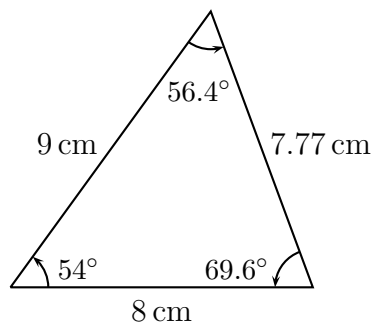

Many of our applications will use the idea of a heading.

Definition: A **heading** is a direction described by north or south, an acute angle, and east or west. It is the direction of the acute angle measured from north or south toward east or west.

$N30^\circ E$

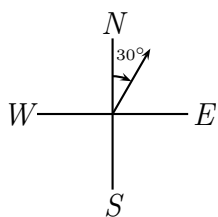

$S80^\circ W$

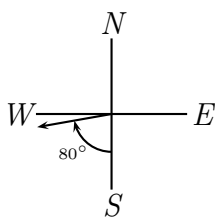

$N50^\circ W$

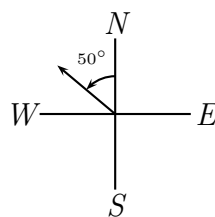

Example 4.9: A pilot flies one hour in the direction N20°E at 200 miles per hour. Then she changes direction to N40°E, flies for half an hour at the same speed, and lands.

a) How far is she from her point of departure?

b) In what direction should she fly to return to her point of departure?

Solution: For these types of problems you should always draw a picture.

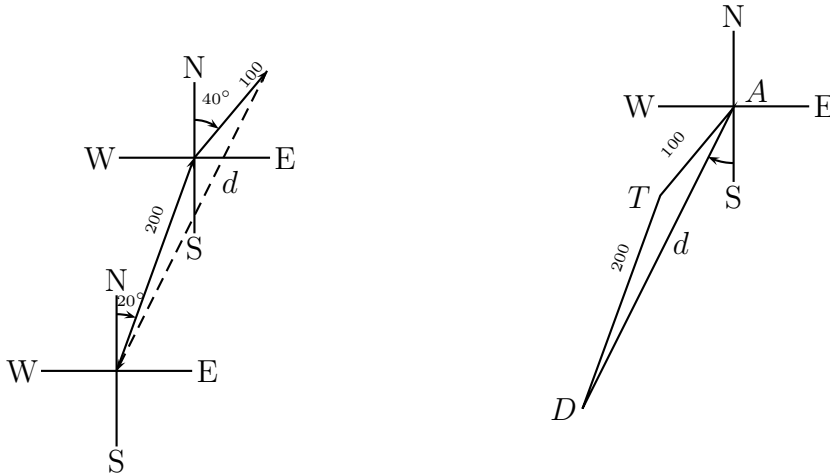

a) We want to know the distance d . To use the Law of Cosines we need to find the angle T (at the turning point).

$$T = 20^\circ + 90^\circ + 50^\circ = 160^\circ$$

$$d^2 = 200^2 + 100^2 - 2 \cdot 200 \cdot 100 \cdot \cos(160^\circ) \approx 87587.7$$

$$\Rightarrow d \approx 296 \text{ miles}$$

b) Clearly she needs to go southwest. To find the exact direction we first need the angle in the triangle at her arrival point, A .

$$A \approx \cos^{-1} \left(\frac{100^2 + 296^2 - 200^2}{2 \cdot 100 \cdot 296} \right) \approx 13^\circ$$

$40^\circ - 13^\circ = 27^\circ$ so the direction back is: S 27°W.

Example 4.10: Airport B is 300 miles from airport A at a heading of N50°E. A pilot flies due east from A for 100 miles.

- What is the pilot's distance to airport B?
- In what direction should she fly to get to airport B?

$$d^2 = 300^2 + 100^2 - 2 \cdot 300 \cdot 100 \cdot \cos 40^\circ \approx 54037$$

$$d \approx \sqrt{54037} \approx 232.5 \text{ mi}$$

$$B \approx \cos^{-1} \left(\frac{100^2 + 232.5^2 - 300^2}{2 \cdot 100 \cdot 232.5} \right) \approx 124^\circ$$

$$\theta = 124^\circ - 90^\circ = 34^\circ$$

Direction: N34°E

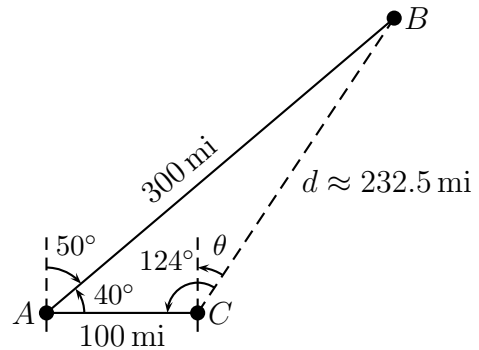

Example 4.11: In your stationary submarine you sight a ship 3 miles away in the direction S 20°W. Five minutes later the ship is only 1 mile away in the direction S 35°E.

- What is the speed of the ship?
- In what direction is the ship moving?

$$d^2 = 3^2 + 1^2 - 2 \cdot 3 \cdot 1 \cdot \cos 55^\circ \approx 6.56$$

$$d \approx \sqrt{6.56} \approx 2.56 \text{ mi}$$

$$\text{speed} \approx \frac{2.56 \text{ mi}}{5 \text{ min}} \cdot \frac{60 \text{ min}}{1 \text{ hr}} \approx 30.7 \text{ mi/hr}$$

$$S_0 \approx \cos^{-1} \left(\frac{3^2 + 2.56^2 - 1^2}{2 \cdot 3 \cdot 2.56} \right) \approx 18.7^\circ$$

$$\theta = 20^\circ + 18.7^\circ = 38.7^\circ$$

Direction: N38.7°E

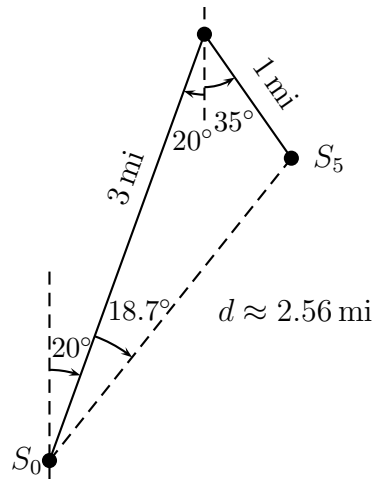

4.2.1 Triangle Area

There are two formulas for finding the area of a general triangle. One applies to SAS triangles, but can be used for SSS triangles. The other only applies to SSS triangles.

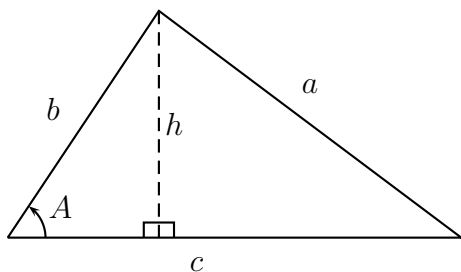

$$\text{area} = \frac{1}{2} \text{base} \cdot \text{height}$$

$$\sin A = \frac{h}{b} \Rightarrow \text{height} = b \sin A$$

$$\text{base} = c$$

$$\Rightarrow \text{area} = \frac{1}{2} cb \sin A$$

The formula $\boxed{\text{triangle area} = \frac{1}{2} bc \sin A}$ can be used to find the area of SSS triangles by first using the Law of Cosines to find the angle A .

Example 4.12: Find the area of the triangle with sides 6 cm, 4 cm, and 7 cm.

Solution:

$$A = \cos^{-1} \left(\frac{6^2 + 7^2 - 4^2}{2 \cdot 6 \cdot 7} \right) \approx 34.8^\circ$$

$$\text{area} = \frac{1}{2} 6 \cdot 7 \cdot \sin 34.8^\circ \approx 12 \text{ cm}^2$$

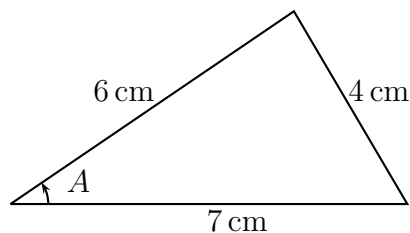

A second method for find the area of a triangle with sides of length a , b , c , is known as **Heron's Formula**.

Let s be the 'semi-perimeter'. $\boxed{s = \frac{1}{2}(a + b + c)}$. Then,

$$\boxed{\text{Area} = \sqrt{s \cdot (s - a) \cdot (s - b) \cdot (s - c)}}$$

Example 4.13: Use Heron's Formula to find the area of the triangle in example 4.12.

Solution:

$$s = \frac{1}{2}(6 + 7 + 4) = 8.5$$

$$\text{area} = \sqrt{8.5 \cdot 2.5 \cdot 1.5 \cdot 4.5} \approx 12 \text{ cm}^2$$

Homework 4.2

1. Use the Law of Cosines to find the remaining side, a .

(a) $b = 15, c = 18, A = 108^\circ$.

(b) $b = 60, c = 30, A = 70^\circ$.

2. Use the Law of Cosines to find the indicated angle.

(a) $a = 10, b = 12, c = 16; A = ?$

(b) $a = 25, b = 20, c = 22; C = ?$

3. Find the areas of the triangles with sides and angles given below.

(a) $b = 15, c = 18, A = 108^\circ$.

(b) $b = 60, c = 30, A = 70^\circ$.

4. Use Heron's Formula to find the areas of the triangles given below.

(a) $a = 10, b = 12, c = 16$

(b) $a = 25, b = 20, c = 22$

5. Two boats leave the same port at the same time. One travels at a speed of 30 mi/hr in the direction $N50^\circ E$, while the other travels at a speed of 26 mi/hr in the direction $S70^\circ E$.

- (a) How far apart are the two boats after one hour?

- (b) In what direction is the second (southern) boat from the first (northern) boat?

6. A fisherman leaves his home port and heads in the direction $N70^\circ W$. He travels 30 miles to reach an island. The next day he sails $N10^\circ E$ for 50 miles, reaching another island.

- (a) How far is the fisherman from his home port?

- (b) In what direction should he sail to return to his home port?

7. A plane flying at an altitude of 1150 feet sees a submarine and a ship on the surface of the ocean. The submarine is at an angle of depression of 28° , and the ship an angle of depression of 36° . The angle between the line-of-sight from the plane to the submarine and the line-of-sight from the plane to the ship is 43° .

How far is the submarine from the ship?

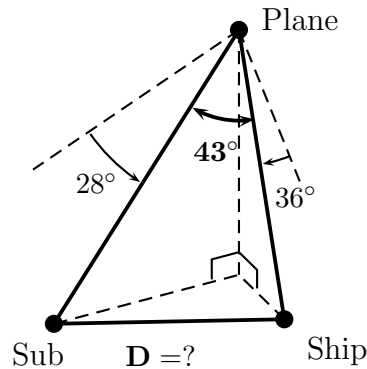

8. A four-sided (but not rectangular) field has sides of lengths 50, 60, 70, and 80 meters. The angle of the corner between the shortest two sides is 100° .

What is the area of the field?

Further practice: Page 518 (sec 6.5) #1-40, 44-46

Solutions Note: Answers are approximate.

1. (a) $a = 26.8$, (b) $a = 57.2$
2. (a) $A = 38.6^\circ$, (b) $C = 57.2^\circ$
3. (a) Area = 128.4, (b) Area = 845.7
4. (a) Area = 59.9, (b) Area = 210.3
5. (a) 28.2 miles, (b) $S 3^\circ E$
6. (a) 62.6 miles, (b) $S 18.2^\circ E$
7. 1679 miles
8. 4077 m^2

4.3 Vectors

Vectors are mathematical objects that have both **magnitude** and **direction**. ‘75 miles per hour’ is not a vector as it has no direction. ‘North’ is not a vector as it has no magnitude. However, ‘North at 75 miles per hour’ can be considered a vector (velocity).

Examples of vectors in physics are velocity, force, displacement, and spin.

We say two vectors are **the same** if they have the same magnitude and direction. If a vector is represented by an arrow from a “tail” to a “head” (as is customary) then this means you can “move the vector around” without changing it.

All the vectors to right are equal, since they all have the same magnitude (length) and direction.

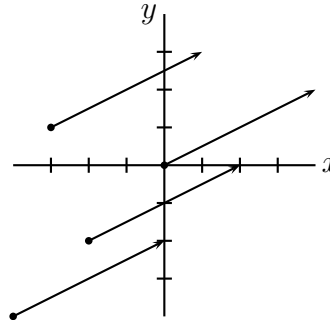

There are two operations that can be performed on vectors to produce a new vector.

1. Scalar multiplication (multiplying by a number).

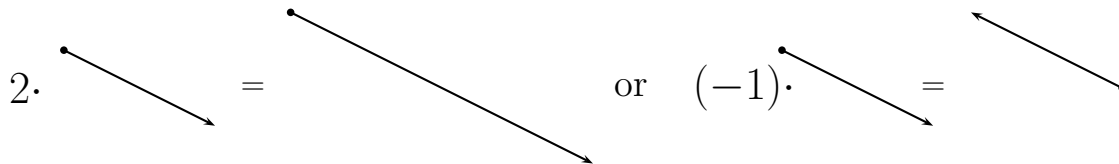

2. Addition (adding two vectors to get a third). Place the two vectors tail to head. The “resultant” vector starts at the tail of the first and goes to the head of the second.

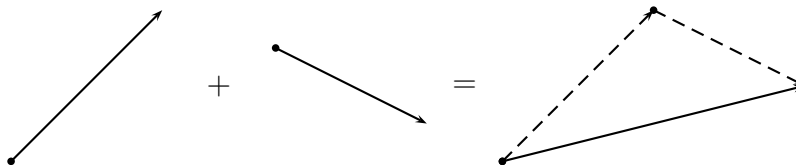

Example 4.14: Let

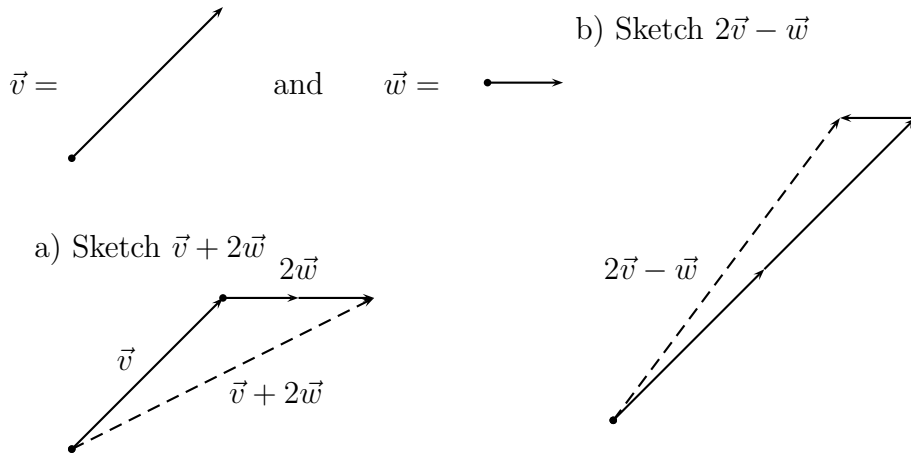

Definition: A vector \vec{v} is written **in components** $\langle v_x, v_y \rangle$ if, when the tail of \vec{v} is placed at the origin, the head points to the point (v_x, v_y) .

Example 4.15: Write the displacement vector, \vec{v} going from the point $(-3, 1)$ to the point $(1, 3)$ in components.

Solution: We'll sketch the vector even though it's not strictly necessary.

To move the vector so its tail is at the origin, we move it right 3 and down 1. Now the vector points at the point $(4, 2)$. Hence,

$$\vec{v} = \langle 4, 2 \rangle$$

Note you can also find this by subtracting the “tail” from the “head”.

$$\vec{v} = \langle 1 - (-3), 3 - 1 \rangle = \langle 4, 2 \rangle$$

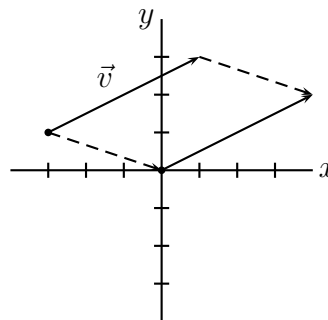

Scalar multiplication and vector addition are very simple when the vectors are written in components.

If $\vec{v} = \langle v_x, v_y \rangle$ and $\vec{w} = \langle w_x, w_y \rangle$ then

1. $c \cdot \vec{v} = \langle cv_x, cv_y \rangle$
2. $\vec{v} + \vec{w} = \langle v_x + w_x, v_y + w_y \rangle$

Example 4.16: Let $\vec{v} = \langle 2, 2 \rangle$ and $\vec{w} = \langle 1, 0 \rangle$.

- a) Find $\vec{v} + 2\vec{w}$ b) Find $2\vec{v} - \vec{w}$

Solution:

$$\begin{aligned} \text{a) } \vec{v} + 2\vec{w} &= \langle 2, 2 \rangle + 2 \cdot \langle 1, 0 \rangle \\ &= \langle 2, 2 \rangle + \langle 2 \cdot 1, 2 \cdot 0 \rangle \\ &= \langle 2 + 2, 2 + 0 \rangle \\ &= \langle 4, 2 \rangle \end{aligned}$$

$$\begin{aligned} \text{b) } 2\vec{v} - \vec{w} &= 2 \cdot \langle 2, 2 \rangle - \langle 1, 0 \rangle \\ &= \langle 4, 4 \rangle + \langle -1, 0 \rangle \\ &= \langle 4 - 1, 4 + 0 \rangle \\ &= \langle 3, 4 \rangle \end{aligned}$$

Definition: A **unit vector** is a vector of length 1.
There are two unit vectors that are particularly important.

$$\vec{i} = \langle 1, 0 \rangle \quad \text{and} \quad \vec{j} = \langle 0, 1 \rangle$$

These vectors provide an alternative way of writing a vector in components.
For example:

$$4\vec{i} + 2\vec{j} = 4\langle 1, 0 \rangle + 2\langle 0, 1 \rangle = \langle 4, 0 \rangle + \langle 0, 2 \rangle = \langle 4, 2 \rangle$$

And, in general

$$v_x\vec{i} + v_y\vec{j} = \langle v_x, v_y \rangle$$

4.3.1 Trigonometric Form

The trigonometric form of a vector is very similar to the trigonometric form of a complex number (See section 3.3). The length of the vector, written $\|\vec{v}\|$, is called the **magnitude** of \vec{v} . (This is almost the same as the **complex modulus** of a complex number.) The **direction angle** of a vector \vec{v} is the angle the vector makes with the positive x -axis when its tail is placed at the origin. (This is almost the same as the **argument** of a complex number.)

Definition: The **magnitude** of a vector $\vec{v} = \langle v_x, v_y \rangle$ is:

$$\|\vec{v}\| = \sqrt{v_x^2 + v_y^2}$$

The **direction angle** of \vec{v} is the angle θ so that

$$\cos \theta = \frac{v_x}{\|\vec{v}\|} \quad \text{and} \quad \sin \theta = \frac{v_y}{\|\vec{v}\|}$$

Definition: The **trigonometric form** of \vec{v} is:

$$\vec{v} = \langle r \cos \theta, r \sin \theta \rangle$$

where $r = \|\vec{v}\|$ and θ is the direction angle of \vec{v} .

Example 4.17: Write the vector $\vec{v} = \langle 4, 2 \rangle$ in the trigonometric form.

Solution: The operations here are exactly the same as if you were finding the trigonometric form of the complex number $4 + 2i$. (See examples 3.32, 3.33, and 3.34.)

$$\|\vec{v}\| = \sqrt{4^2 + 2^2} = \sqrt{20} = 2\sqrt{5}$$

The direction angle will satisfy:

$$\cos \theta = \frac{4}{2\sqrt{5}} = \frac{2}{\sqrt{5}} \quad \text{and} \quad \sin \theta = \frac{2}{2\sqrt{5}} = \frac{1}{\sqrt{5}}$$

You are in quadrant I (since both cosine and sine are positive),
 $\theta = \cos^{-1}\left(\frac{2}{\sqrt{5}}\right) \approx 26.6^\circ$. So,

$$\vec{v} \approx \langle 2\sqrt{5} \cos 26.6^\circ, 2\sqrt{5} \sin 26.6^\circ \rangle$$

Example 4.18: Find the trigonometric form of the vector $\vec{u} = \langle -3, 4 \rangle$.

$$\|\vec{u}\| = \sqrt{(-3)^2 + 4^2} = \sqrt{25} = 5$$

The direction angle will satisfy:

$$\cos \theta = \frac{-3}{5} = -\frac{3}{5} \quad \text{and} \quad \sin \theta = \frac{4}{5}$$

The angle is in quadrant II (since cosine is negative and sine positive),
 $\text{ref} = \cos^{-1}\left(+\frac{3}{5}\right) \approx 53.1^\circ$. Quadrant II means $\theta \approx 126.9^\circ$. So,

$$\vec{u} \approx \langle 5 \cos 126.9^\circ, 5 \sin 126.9^\circ \rangle$$

Example 4.19: Write the vector \vec{w} with magnitude 14 and direction angle 210° in components.

Solution: $r = 14$ and $\theta = 210^\circ$, so

$$\vec{w} = \langle 14 \cos 210^\circ, 14 \sin 210^\circ \rangle = \langle -7\sqrt{3}, -7 \rangle$$

The trigonometric form of a vector does not allow you to multiply or take roots of the vector (as it does for complex numbers). The trigonometric form is still important because vectors are very often presented in this form.

Example 4.20: A plane is flying due north at 300 miles per hour when it is struck by a 40 mile per hour tail-wind in the direction N30°W. What is the true speed and direction of the plane (with respect to the ground)?

Solution: The true velocity of the plane will be the vector sum of the plane's velocity in still air (300mph north) with the velocity of the wind (40mph N30°W).

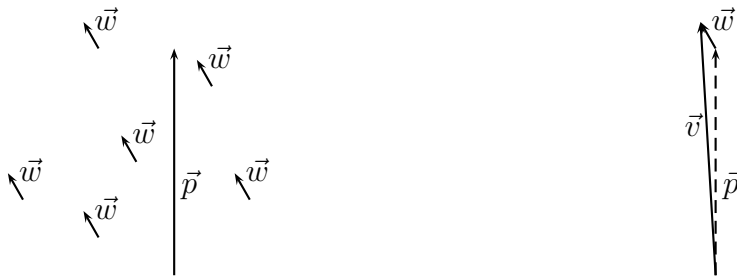

We must turn the two velocities into components, add them, then turn the result back into the trig form (speed and direction).

$$\begin{array}{r} \vec{p} = \langle 300 \cos 90^\circ, 300 \sin 90^\circ \rangle = \quad \langle 0, \quad 300 \rangle \\ + \vec{w} = \langle 40 \cos 120^\circ, 40 \sin 120^\circ \rangle \approx \langle -20, \quad 34.64 \rangle \\ \hline \Rightarrow \vec{v} \approx \langle -20, \quad 334.64 \rangle \end{array}$$

$$\|\vec{v}\| \approx \sqrt{(-20)^2 + (334.64)^2} \approx 335.2 \text{ mph}$$

The reference angle for the direction angle is $\cos^{-1} \left(\frac{20}{335.2} \right) \approx 86.6^\circ$.
Cosine negative, sine positive is quadrant II, so

$$\theta \approx 180^\circ - 86.6^\circ = 93.4^\circ$$

So the true direction of the plane is N3.4°W. (The wind is pushing the plane 3.4° off-course to the west as well as adding ≈ 35 mph to its speed.)

Example 4.21: A river flows due east at 3 miles per hour. A boat is crossing the river diagonally with its prow pointed in the direction S30°W. In still water the boat moves at 10 miles per hour.

What is the true velocity of the boat?

Let \vec{b} be the velocity of the boat in still water. Southwest is in quadrant III, so the direction angle for \vec{b} is $270^\circ - 30^\circ = 240^\circ$. If \vec{c} is the velocity of the current, then the true velocity is

$$\begin{array}{r} \vec{b} = \langle 10 \cos 240^\circ, 10 \sin 240^\circ \rangle \approx \langle -5, -8.66 \rangle \\ + \vec{c} = \langle 3 \cos(0^\circ), 3 \sin(0^\circ) \rangle = \langle 3, 0 \rangle \\ \hline \Rightarrow \vec{v} \approx \langle -2, -8.66 \rangle \end{array}$$

$$\|\vec{v}\| \approx \sqrt{(-2)^2 + (-8.66)^2} \approx 8.89 \text{ mph}$$

The reference angle for the direction angle is $\cos^{-1}\left(\frac{2}{8.89}\right) \approx 77.0^\circ$. Cosine and sine are negative, making it in quadrant III, so

$$\theta \approx 180^\circ + 77.0^\circ = 257.0^\circ$$

Thus the true direction of the boat is S13°W.

Example 4.22: Two tugboats are pulling a barge. The first pulls in the direction S60°E with a force of magnitude 3200 pounds. The second pulls with a force of magnitude 4000 pounds.

If the barge is to go straight east, in what direction is the second tug pulling?

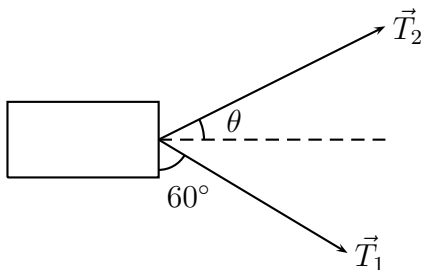

$$\begin{array}{r} \vec{T}_1 = \langle 3200 \cos(-30^\circ), 3200 \sin(-30^\circ) \rangle \\ + \vec{T}_2 = \langle 4000 \cos \theta, 4000 \sin \theta \rangle \\ \hline \Rightarrow \vec{T}_1 + \vec{T}_2 \approx \langle 2771.3 + 4000 \cos \theta, -1600 + 4000 \sin \theta \rangle \end{array}$$

Moving directly east means that the *NS* component (*y* component) is zero. Thus,

$$-1600 + 4000 \sin \theta = 0 \Rightarrow \theta = \sin^{-1}\left(\frac{1600}{4000}\right) \approx 23.6^\circ$$

So, N66.4°E.

4.3.2 Static Equilibrium

The state of **static equilibrium** occurs when all the forces on an object balance out so that the object remains stationary. Static equilibrium problems give us some interesting applications of both vectors and trigonometric geometry.

Example 4.23: A 40 pound child is sitting on a swing. The child's mother is pulling horizontally on the child so that the swing is stationary, making an angle of 35° with the vertical. What is the magnitude of the force the mother is exerting? What is the magnitude of the tension in the swing?

Solution: There are three forces on the child: the weight of the child (40 pounds downward), the pull of the mother (? pounds backward), and the tension in the swing (? pounds upward at an angle of 35°). They cancel exactly since the child is stationary — thus static equilibrium.

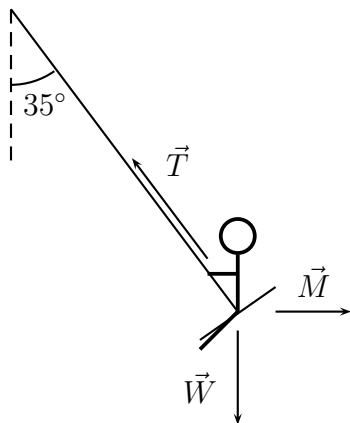

Putting vectors head-to-tail
(thus adding them):

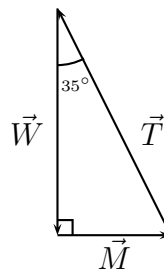

$$\tan 35^\circ = \frac{\|\vec{M}\|}{\|\vec{W}\|} = \frac{\|\vec{M}\|}{40}$$

$$\Rightarrow \|\vec{M}\| = 40 \tan 35^\circ \approx 28 \text{ lbs}$$

$$\cos 35^\circ = \frac{\|\vec{W}\|}{\|\vec{T}\|} = \frac{40}{\|\vec{T}\|}$$

$$\Rightarrow \|\vec{T}\| = \frac{40}{\cos 35^\circ} \approx 48.8 \text{ lbs}$$

Example 4.23 can also be solved using the techniques of the previous section (though it's harder). Writing the three vectors in components and adding:

$$\begin{array}{r} \vec{M} = \langle \|\vec{M}\|, 0 \rangle \\ \vec{W} = \langle 0, -40 \rangle \\ +\vec{T} = \langle \|\vec{T}\| \cos 125^\circ, \|\vec{T}\| \sin 125^\circ \rangle \\ \hline \langle \|\vec{T}\| \cos 125^\circ + \|\vec{M}\|, \|\vec{T}\| \sin 125^\circ - 40 \rangle = \langle 0, 0 \rangle \end{array}$$

Thus,

$$\|\vec{T}\| \sin 125^\circ - 40 = 0 \Rightarrow \|\vec{T}\| = \frac{40}{\sin 125^\circ} \approx 48.8 \text{ lbs}$$

and

$$\|\vec{T}\| \cos 125^\circ + \|\vec{M}\| = 0 \Rightarrow \|\vec{M}\| = -\|\vec{T}\| \cos 125^\circ \approx 28 \text{ lbs}$$

Example 4.24: A 2 pound Christmas ornament hangs on a wire, pulling it downward. The wire makes a 42° angle with the horizontal to the left, and a 22° angle with the horizontal to the right.

What are the tensions on the wires to the left and right?

(Hint: Make a triangle with the vectors and use the Law of Sines.)

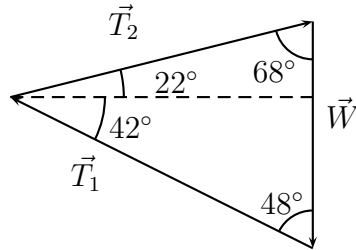
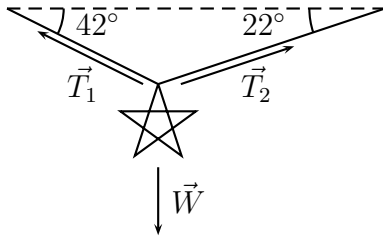

$$\frac{\sin(64^\circ)}{\|\vec{W}\|} = \frac{\sin(68^\circ)}{\|\vec{T}_1\|} = \frac{\sin(48^\circ)}{\|\vec{T}_2\|}$$

Since $\|\vec{W}\| = 2$ lbs,

$$\|\vec{T}_1\| = \frac{2 \sin(68^\circ)}{\sin(64^\circ)} \approx 2.06 \text{ lbs}$$

$$\|\vec{T}_2\| = \frac{2 \sin(48^\circ)}{\sin(64^\circ)} \approx 1.65 \text{ lbs}$$

Homework 4.3

1. Sketch the vectors below.



(a) $\vec{v} + \vec{w}$

(b) $\vec{v} + 2\vec{w}$

(c) $\vec{v} - \vec{w}$

(d) $3\vec{w} - 2\vec{v}$

2. Calculate the vectors in components.

$$\vec{v} = \langle 3, 1 \rangle \quad \vec{w} = \langle 1, -1 \rangle$$

(a) $\vec{v} + \vec{w}$

(b) $\vec{v} + 2\vec{w}$

(c) $\vec{v} - \vec{w}$

(d) $3\vec{w} - 2\vec{v}$

3. A cruise ship is moving due north at 10 miles/hour. A child on the deck of the ship runs S 50° E at 5 miles/hour. What is the true velocity of the child?

4. A plane is flying S 25° W at 200 miles/hour when it runs into a head wind blowing N 51° E at 35 miles/hour. What is the true velocity of the plane?

5. A barge is floating in a harbor in still water. Two tugboats hook onto the barge. The first tugboat applies a force of magnitude 2000 pounds in the direction $N25^\circ W$. The second tugboat applies a force in the direction $N15^\circ E$.

(a) Say the second tugboat applies a force of magnitude 1800 pounds. In what direction will the barge move?

(b) What magnitude of force must the second tugboat apply to make the barge move due north?

6. A 10 pound lamp is attached to the ceiling and one wall with cords. The cord to the wall is horizontal while the cord to the ceiling makes a 25° angle with the vertical. What are the tensions on the two cords?

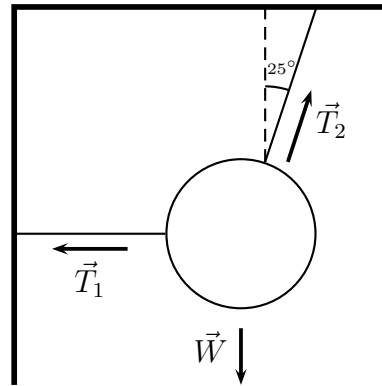

7. A barge is floating in a river. The current is applying a force of magnitude 1000 pounds due west. Two tugboats are attached to the barge and holding it stationary in the river. One tugboat is pulling in the direction $N70^\circ E$; the other $S65^\circ E$.

What are the magnitudes of the forces applied by the two tugboats?

Solutions Note: Answers are approximate.

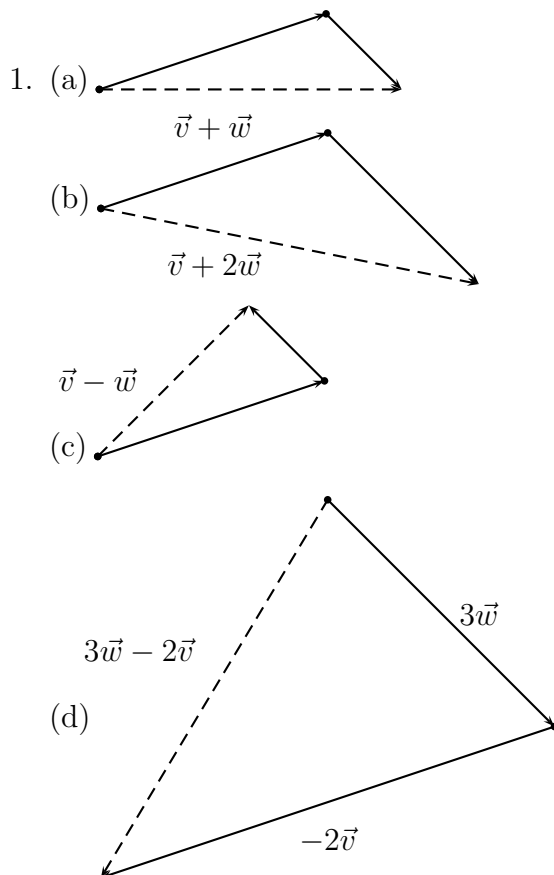

1. (a) $\langle 4, 0 \rangle$, (b) $\langle 5, -1 \rangle$, (c) $\langle 2, 2 \rangle$,
(d) $\langle -3, -5 \rangle$

3. The velocity vector is $\langle 3.830, 6.79 \rangle$, the true speed of the child is about 7.8 mph.

4. The resultant velocity is $\langle -57.324, -159.235 \rangle$, the true ground speed is about 169.2 mph and the true course is $S20^\circ W$

5. (a) $N 6^\circ E$, (b) About 3266 lbs

6. $T_1 \approx 4.66$ lbs and $T_2 \approx 11.03$ lbs

7. $T_1 \approx 598$ lbs and $T_2 \approx 484$ lbs